



BSI Standards Publication

Cathodic protection of external surfaces of above ground storage tank bases in contact with soil or foundations

NO COPYING WITHOUT BSI PERMISSION EXCEPT AS PERMITTED BY COPYRIGHT LAW

National foreword

This British Standard is the UK implementation of EN 16299:2013.

The UK participation in its preparation was entrusted to Technical Committee GEL/603, Cathodic protection.

A list of organizations represented on this committee can be obtained on request to its secretary.

This publication does not purport to include all the necessary provisions of a contract. Users are responsible for its correct application.

© The British Standards Institution 2013.
Published by BSI Standards Limited 2013.

ISBN 978 0 580 72888 4

ICS 77.060

Compliance with a British Standard cannot confer immunity from legal obligations.

This British Standard was published under the authority of the Standards Policy and Strategy Committee on 30 April 2013.

Amendments issued since publication

Date	Text affected
------	---------------

EUROPEAN STANDARD

EN 16299

NORME EUROPÉENNE

EUROPÄISCHE NORM

April 2013

ICS 77.060

English Version

Cathodic protection of external surfaces of above ground storage tank bases in contact with soil or foundations

Protection cathodique des surfaces externes des fonds de réservoirs de stockage aériens en contact avec le sol ou les fondations

Kathodischer Korrosionsschutz für erdberührte und gegründete Außenflächen von oberirdischen Lagertanks aus Stahl

This European Standard was approved by CEN on 23 February 2013.

CEN members are bound to comply with the CEN/CENELEC Internal Regulations which stipulate the conditions for giving this European Standard the status of a national standard without any alteration. Up-to-date lists and bibliographical references concerning such national standards may be obtained on application to the CEN-CENELEC Management Centre or to any CEN member.

This European Standard exists in three official versions (English, French, German). A version in any other language made by translation under the responsibility of a CEN member into its own language and notified to the CEN-CENELEC Management Centre has the same status as the official versions.

CEN members are the national standards bodies of Austria, Belgium, Bulgaria, Croatia, Cyprus, Czech Republic, Denmark, Estonia, Finland, Former Yugoslav Republic of Macedonia, France, Germany, Greece, Hungary, Iceland, Ireland, Italy, Latvia, Lithuania, Luxembourg, Malta, Netherlands, Norway, Poland, Portugal, Romania, Slovakia, Slovenia, Spain, Sweden, Switzerland, Turkey and United Kingdom.



EUROPEAN COMMITTEE FOR STANDARDIZATION
COMITÉ EUROPÉEN DE NORMALISATION
EUROPÄISCHES KOMITEE FÜR NORMUNG

Management Centre: Avenue Marnix 17, B-1000 Brussels

Contents	Page
Foreword.....	4
Introduction	5
1 Scope.....	6
2 Normative references.....	6
3 Terms and definitions	7
4 Abbreviations and symbols.....	8
5 Competence of personnel.....	8
6 Corrosion risks and their prevention by cathodic protection.....	9
6.1 General	9
6.2 Corrosion risks of external surfaces of above ground storage tank bottoms in contact with soil or foundations	9
7 Pre-requisites for the application of cathodic protection.....	12
7.1 General	12
7.2 New tanks	12
7.3 Existing tanks.....	15
7.4 Tank design and feasibility of cathodic protection	17
8 Criteria for cathodic protection and measurement techniques	18
8.1 General	18
8.2 Criteria	18
8.3 Alternative criteria and methods	19
9 Design of cathodic protection systems	20
9.1 General	20
9.2 Structure details and data.....	21
9.3 Environment.....	22
9.4 Electrical isolation.....	22
9.5 Current requirements.....	23
9.6 Cathodic protection systems and anode configuration	23
9.7 Cable connections to the tank.....	23
9.8 Reference electrodes, coupons and test stations	24
9.9 Explosion hazard prevention.....	25
9.10 Galvanic anode systems.....	26
9.11 Impressed current systems	26
9.12 Cables.....	27
9.13 Interference	28
10 Installation of cathodic protection systems.....	28
10.1 General	28
10.2 Installation of cables.....	29
10.3 Isolating joints.....	30
10.4 Anodes	30
10.5 Impressed current stations.....	31
10.6 Test stations, measuring points, permanent reference electrodes, and coupons.....	31
10.7 Bonding	32
10.8 Labelling.....	32
10.9 Installation checks	32
10.10 As-built documentation	33
11 Commissioning	33

11.1	General	33
11.2	Preliminary checking	33
11.3	Start-up	34
11.4	Verification of the cathodic protection effectiveness	35
11.5	Determination of relevant measuring points	35
11.6	Commissioning documents	35
12	Inspection and maintenance	35
12.1	General	35
12.2	Inspection	35
12.3	Maintenance	37
Annex A	(informative) Groundbed data	39
A.1	General considerations	39
A.2	Types of ground beds	39
A.3	Anodes types	40
	Bibliography	42

Foreword

This document (EN 16299:2013) has been prepared by Technical Committee CEN/TC 219 "Cathodic protection", the secretariat of which is held by BSI.

This European Standard shall be given the status of a national standard, either by publication of an identical text or by endorsement, at the latest by October 2013, and conflicting national standards shall be withdrawn at the latest by October 2013.

Attention is drawn to the possibility that some of the elements of this document may be the subject of patent rights. CEN [and/or CENELEC] shall not be held responsible for identifying any or all such patent rights.

According to the CEN-CENELEC Internal Regulations, the national standards organisations of the following countries are bound to implement this European Standard: Austria, Belgium, Bulgaria, Croatia, Cyprus, Czech Republic, Denmark, Estonia, Finland, Former Yugoslav Republic of Macedonia, France, Germany, Greece, Hungary, Iceland, Ireland, Italy, Latvia, Lithuania, Luxembourg, Malta, Netherlands, Norway, Poland, Portugal, Romania, Slovakia, Slovenia, Spain, Sweden, Switzerland, Turkey and the United Kingdom.

Introduction

It is important to maintain the integrity of above ground storage steel tanks (AST) for environmental and economical reasons.

This European Standard applies only for external corrosion prevention, which is independent of internal corrosion issues.

During the design of any new tank, a complete corrosion control study including the use of cathodic protection methods should be performed for preventing external corrosion of the surfaces in contact with soil, cushion or foundations. When cathodic protection is adopted, it is an effective method if designed, implemented, operated and maintained in accordance with this standard. The pre-requisites for the cathodic protection should be taken into account from the basic design. In case cathodic protection is not adopted, a documented technical justification on the equivalent effectiveness of alternative methods should be given.

For existing tanks, corrosion risks of external surfaces of tank bottoms may be important and possibly cause leaks, depending on the nature of soil, cushion, foundations, design of tank, and other equipment electrically connected to it such as an earthing system. Depending on the design and environmental conditions of the tank as detailed in the present standard, cathodic protection may be effective to mitigate corrosion when designed, implemented, operated and maintained in accordance with this standard.

Cathodic protection is aimed at supplying a direct current (d.c.) to the steel surface such that the steel-to-electrolyte potential is lowered to values where corrosion becomes insignificant.

Cathodic protection of above ground storage steel tanks is normally used in combination with a compatible protective coating system to protect the external surfaces of above ground storage steel tank bottoms from corrosion.

1 Scope

This European Standard defines the conditions necessary for an effective application of the cathodic protection method to mitigate corrosive attacks on the external surfaces of above ground storage steel tank bottoms in contact with soil, cushion or foundations.

This European Standard specifies the requirements for the design, implementation, commissioning, operation and maintenance of such a cathodic protection system.

This European Standard applies both for new and existing tanks.

NOTE 1 This European Standard is not applicable to reinforced concrete above ground storage tanks for which EN ISO 12696 applies.

NOTE 2 Detailed information concerning measurement techniques of cathodic protection given in EN 13509 are referred to in the present standard.

NOTE 3 Cathodic protection of internal surfaces of above ground storage steel tanks storing waters is addressed in EN 12499.

NOTE 4 Cathodic protection of external surfaces of buried tanks is addressed in EN 13636.

2 Normative references

The following documents, in whole or in part, are normatively referenced in this document and are indispensable for its application. For dated references, only the edition cited applies. For undated references, the latest edition of the referenced document (including any amendments) applies.

EN 13509, *Cathodic protection measurement techniques*

EN 14015, *Specification for the design and manufacture of site built, vertical, cylindrical, flat-bottomed, above ground, welded, steel tanks for the storage of liquids at ambient temperature and above*

EN 14505, *Cathodic protection of complex structures*

EN 50162, *Protection against corrosion by stray current from direct current systems*

EN 60079-0, *Explosive atmospheres — Part 0: Equipment — General requirements (IEC 60079-0)*

EN 60079-1, *Explosive atmospheres — Part 1: Equipment protection by flameproof enclosures "d" (IEC 60079-1)*

EN 60079-2, *Explosive atmospheres — Part 2: Equipment protection by pressurized enclosures "p" (IEC 60079-2)*

EN 60079-5, *Explosive atmospheres — Part 5: Equipment protection by powder filling "q" (IEC 60079-5)*

EN 60079-7, *Explosive atmospheres — Part 7: Equipment protection by increased safety "e" (IEC 60079-7)*

EN 60079-10-1, *Explosive atmospheres — Part 10-1: Classification of areas — Explosive gas atmospheres (IEC 60079-10-1)*

EN 60079-11, *Explosive atmospheres — Part 11: Equipment protection by intrinsic safety "i" (IEC 60079-11)*

EN 60079-14, *Explosive atmospheres — Part 14: Electrical installations design, selection and erection (IEC 60079-14)*

EN 60079-15, *Explosive atmospheres — Part 15: Equipment protection by type of protection "n"* (IEC 60079-15)

EN 60079-18, *Explosive atmospheres — Part 18: Equipment protection by encapsulation "m"* (IEC 60079-18)

EN 60079-25, *Explosive atmospheres — Part 25: Intrinsically safe electrical systems* (IEC 60079-25)

EN 60587, *Electrical insulating materials under severe ambient conditions — Test methods for evaluating resistance to tracking and erosion* (IEC 60587)

EN 61558-1, *Safety of power transformers, power supplies, reactors and similar products — Part 1: General requirements and tests* (IEC 61558-1)

EN ISO 8044, *Corrosion of metals and alloys — Basic terms and definitions* (ISO 8044)

3 Terms and definitions

For the purposes of this document, the terms and definitions given in EN ISO 8044 and EN 14015 and the following apply.

3.1

cushion

material in contact with the bottom of an aboveground storage tank

3.2

foundations

buried construction aimed at mechanically supporting locally the above ground storage tank

3.3

hazardous area

area in which an explosive atmosphere is present, or may be expected to be present, in quantities such as to require special precautions for the construction, installation and use of equipment

Note 1 to entry: For the purposes of this standard, an area is a three-dimensional region or space.

3.4

IR drop

voltage that is the product of all currents flowing through the cathodic protection circuit and the resistance of the current path (mainly the electrolyte and the tank bottom)

Note 1 to entry: This is derived from Ohm's law ($U = I \times R$).

3.5

IR free potential

polarised potential

structure to electrolyte potential without the voltage error caused by the IR drop due to the protection current or any other current

3.6

local earthing system

local earthing system for the structure under consideration which is electrically separated from any other general earthing

3.7

shield

conductive or non conductive structure or object, which modifies the protection current distribution on a structure to be protected

4 Abbreviations and symbols

API	American Petroleum Institute
AST	Above ground storage tank
E	Potential
R	Resistance
a.c.	Alternating current
d.c.	Direct current
E_{Cu}	Metal or structure to electrolyte potential with respect to a copper/saturated copper sulphate reference electrode
E_H	Metal or structure to electrolyte potential with respect to a normal hydrogen reference electrode
$E_{IR\ free}$	IR free potential
E_{cor}	Free corrosion potential
E_{off}	OFF potential
E_{on}	ON potential
E_p	Protection potential
HVDC	High Voltage Direct Current
IEC	International Electrotechnical Commission
MMO	Mixed Metal Oxides
T	Temperature
t	Thickness of cushion
ρ	Resistivity

5 Competence of personnel

Personnel who undertake the design, supervision of installation, commissioning, supervision of operation, measurements, monitoring and supervision of maintenance of cathodic protection systems shall have the appropriate level of competence for the tasks undertaken.

EN 15257 constitutes a suitable method of assessing and certifying competence of cathodic protection personnel which may be utilised.

Competence of cathodic protection personnel to the appropriate level for tasks undertaken should be demonstrated by certification in accordance with EN 15257 or by another equivalent prequalification procedure.

6 Corrosion risks and their prevention by cathodic protection

6.1 General

The corrosion rate of a metal in soil or water is a function of the potential, E , of the material in its surrounding electrolytic environment. The corrosion rate decreases as the potential is shifted in the more negative direction. This negative potential shift is achieved by feeding direct current from anodes via the soil or water to the metal surface of the structure to be protected. In the case of coated structures, the current mainly flows to the metal surface at coating pinholes and holidays. The protection current can be provided by impressed current systems or galvanic anodes.

The corrosion risks and the need and feasibility of cathodic protection for a given above ground storage tank are directly linked to the mechanical design of the storage tank bottoms and to its environment.

The cushion material in contact with the tank has a significant effect on external corrosion of the tank bottom and can influence the effectiveness and applicability of external cathodic protection.

During the design of any new tank, a complete corrosion control study including the use of cathodic protection shall be performed. In case cathodic protection is not adopted, a documented technical justification on the equivalent effectiveness of alternative methods shall be given.

Cathodic protection is an effective method of corrosion prevention if electrical protection current reaches the whole surface of the tank bottom. Factors that may reduce or prevent the flow of current are:

- concrete foundations (shielding effect depending on anode location);
- asphalt or oiled sand made cushions;
- impervious membranes (depending on anode location);
- new tank bottoms installed above the original tank bottom and therefore not in contact with the cushion;
- excessive current demand caused by external structures such as earthing networks, especially when made of bare copper, and contact with steel reinforcement;
- interference from foreign cathodic protection systems;
- trapped air between the tank bottom and the cushion.

6.2 Corrosion risks of external surfaces of above ground storage tank bottoms in contact with soil or foundations

6.2.1 General

The external bottom of a tank is in contact with the cushion and, therefore, just like any other structure in contact with an electrolyte, it is subject to corrosion. The major factors to consider for an assessment of the corrosive conditions are the corrosivity of the cushion in contact with the bottom, galvanic effects, differential aeration and environmental conditions.

The tank bottom is subjected to large load variations caused by loading and discharge of the tank. It is also subject to temperature changes with the seasons and the stored product. The tank bottom is flexible, if not well supported by the soil and/or the cushion, except at its periphery where it is very rigid due to the weight of the shell on the concrete ring foundation. To a lesser degree, some rigidity exists at the periphery of each plate due to overlapping and lap-welds. This can result in vertical motions with possible introduction of moist air, which promotes corrosion.

6.2.2 Cushion

The assessment of the corrosion risks shall be based on both the imported materials constituting the cushion and the native surrounding soil which can pollute the cushion by capillary action and can include:

- the determination of the nature and hydrogeology of the area. These characteristics express the possibility of moisture and water flowing, or the ingress of air under the bottom of the tank;
- retention of precipitation in the bund area;
- resistivity measurements of the cushion and surrounding soil;
- likelihood of sulphate reducing bacteria development.

Soil conditions contributing to the so-called “corrosion load” (sum of all the effects on a steel structure due to a corrosive medium) are developed in EN 12501-1 and EN 12501-2. This standard enables classification of the risks of corrosion in three groups (low, medium and high “corrosion load”). It gives some guidance for assessing “corrosion load” from pH and resistivity of soil samples. Figure 1 reproduces Table 1 of EN 12501-2:2003 for pH less than 9,5.

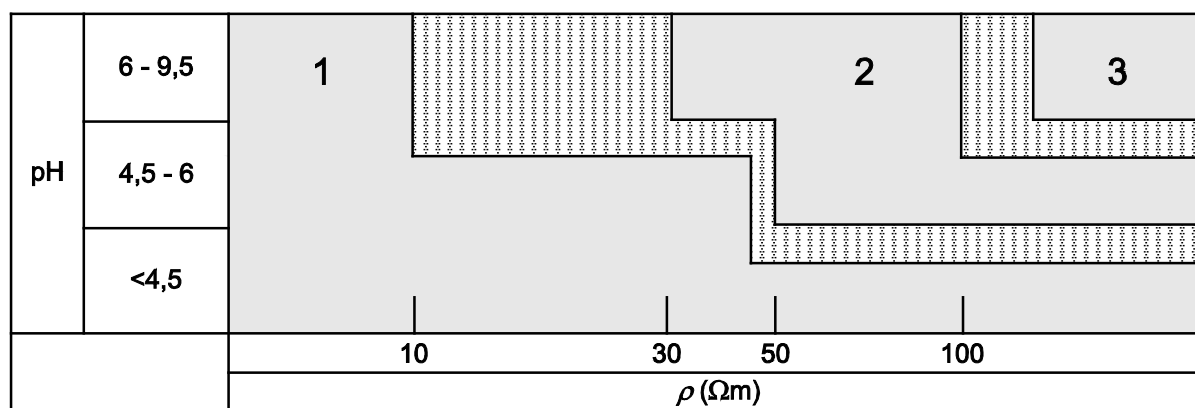

Key

- 1 high
- 2 medium
- 3 low
- ρ^* Minimum resistivity value after adding deionised water (Ω .m)

Figure 1 — Corrosivity of soil (free corrosion without concentration cell from EN 12501-2:2003)

NOTE 1 API Standard 651 third edition [2] recommends the use of resistivity for a qualitative classification of soil “potential corrosion activity” as follows:

- resistivity < 5 Ω .m: very corrosive;
- resistivity from 5 Ω .m to 10 Ω .m: corrosive;
- resistivity from 10 Ω .m to 20 Ω .m: moderately corrosive;
- resistivity from 20 Ω .m to 100 Ω .m: mildly corrosive;
- resistivity > 100 Ω .m: progressively less corrosive.

NOTE 2 API Standard 651 second edition [1] related to chloride and sulphate concentrations: chlorides between 0,03 % to 0,1 % or sulphates between 0,1 % to 0,5 % were considered corrosive and chlorides higher than 0,1 % or sulphates higher than 0,5 % were considered very corrosive.

The ingress of moist air in the cushion at the peripheral areas increases the corrosion rate.

6.2.3 Galvanic effects

Galvanic cells can develop on the bottom of the tank itself due to different potentials between the steel of the plates and the weld metal, and possibly due to metallurgical differences in the metal of adjacent plates that make up the tank bottom.

The lower sides of the tank bottom are often coated with a bituminous solution. When this product is burnt during welding operations it can turn into conductive carbon particles, which will form a galvanic cell with the tank bottom.

Galvanic cells can exist if the tank is directly electrically linked to earthing systems made of copper or other metals or alloys such as stainless steels which are more cathodic than steel. The bottom surface can be corroded as illustrated in Figure 2.

Galvanic cells can exist if the tank is in contact with steel reinforcement of a concrete ring beam.

NOTE Generally, on new tanks, the presence of a waterproof plastic membrane spread out under the tank cushion before its construction minimises ingress of water or other contaminants from the native surrounding soil towards the cushion material and suppress, by shielding effect, galvanic cells caused by earthing systems. See 7.2.4 for more detailed information.

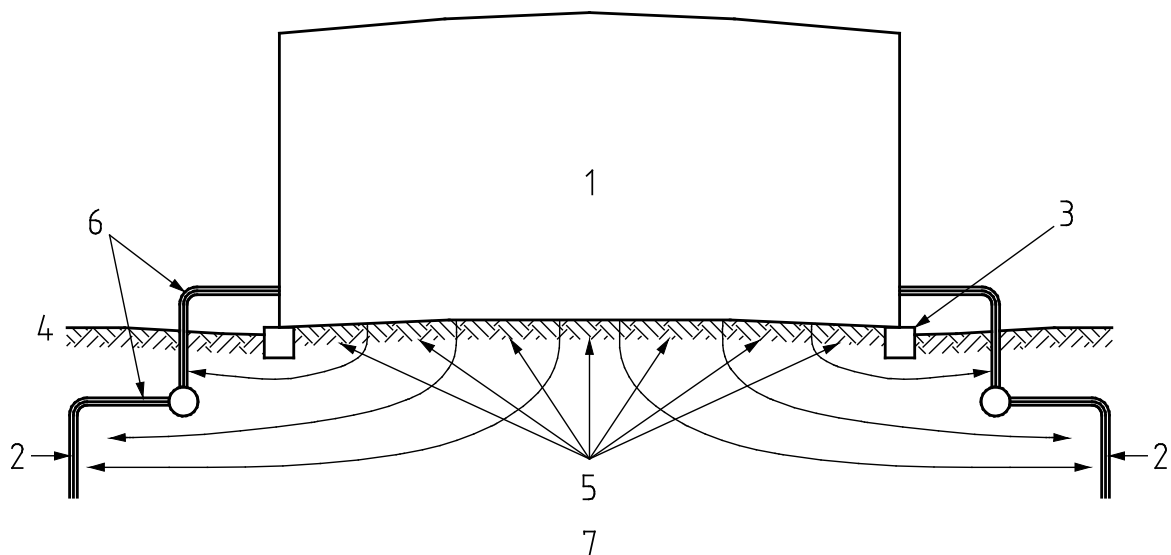

Key

- | | |
|-----------------------------|-------------------------------|
| 1 above ground storage tank | 4 soil |
| 2 cathode | 5 anodic area |
| 3 concrete ring beam | 6 bare copper earthing system |
| | 7 wet soil |

Figure 2 — Galvanic corrosion of external surface of tank bottom due to coupling with copper earthing system

6.2.4 Stray currents

The presence of stray currents may result in local accelerated corrosion. When cathodic protection is applied, greater current requirements than those required under natural conditions may be necessary. Possible sources of stray current include dc operated rail systems and mining operations, other cathodic protection systems, welding equipment, and high-voltage direct current (HVDC) transmission systems. More details on risks and their mitigation are given in EN 50162.

7 Pre-requisites for the application of cathodic protection

7.1 General

When cathodic protection is adopted for new tanks, its design shall be complete and approved before any construction works begins.

The detailed design of the cathodic protection system shall take into account the type of cushion, foundations and earthing connections to the tank. The effectiveness of the applied cathodic protection system can be adversely affected by the construction methods and materials. The effectiveness of the cathodic protection system shall be demonstrated by conforming to the criteria specified in Clause 8.

Measurement of the tank bottom potentials is best achieved by the use of permanent reference electrodes and coupons placed close to the tank bottom during construction. Other techniques can be used, such as drilled tubes filled with an electrolyte and a movable reference electrode, but due consideration should be taken of the effectiveness of the measurements.

For existing tanks, cathodic protection can be effective in mitigating the corrosion although there may be limitations imposed by the nature of the cushion, availability of correct locations for the installation of anodes and the difficulties imposed by earth connections made to the tanks. Criteria in Clause 8 shall be applied.

7.2 New tanks

7.2.1 Tank cushion material

The tank cushion material is required to provide a soft base for the tank bottom with a low corrosion loading and allowing efficient flow of a cathodic protection current. The best material for this is cleaned and washed sand. The sand shall be of uniform small grain size and free from stones and other debris. This is discussed in EN 14015. After the laying of the sand, it is important that no construction debris, such as welding rods or other metallic objects, is present before compacting the sand. Stones and debris will cause localised corrosion when in contact with the bottom of the tank, may damage anodes laid in the sand beneath the tank and will impede the flow of cathodic protection current. The sand shall be washed, and screened to ensure uniform particle size. In particular the sand should have a chloride content of less than 0,01 % with a pH higher than 6.5 and shall not be impregnated with any form of oil or coagulant, e.g. coal-tar enamel, asphalt, crude oil, oiled-sand cushions. The addition of oil and coagulant will prevent cathodic protection current reaching the tank bottom and will provide no benefits in preventing corrosion

Samples of the sand shall be subject to soil resistivity measurement, chloride content measurement and pH measurement.

Air introduced due to vertical motions of tank bottoms during loading and discharge can prevent access of cathodic protection current and consequently have an adverse effect on the effectiveness of the cathodic protection. In order to avoid this, it is recommended that when sand is used for the cushion its granular size is selected such that it maintains a good contact with the plates even at the level of the laps.

7.2.2 Ring beam of the tank

The main purpose of the concrete ring beam is to support the shell and to avoid the spread of the cushion. Direct electrical contact between the tank and the rebar creates a galvanic cell between the bottom plates and the ring beam steel reinforcement.

This contact may be avoided, or at least limited, by sufficient concrete thickness over the external layer of steel reinforcement bars (rebars) and/or the use of insulation, or high duty coatings on the steel plate and/or on the concrete ring.

Additional cathodic protection current may be required to compensate for the current losses to the steel reinforcement and to eliminate the galvanic corrosion cells.

NOTE The ring beam steel reinforcement might have its own cathodic protection system applied to prevent the corrosion of the rebars in highly corrosive soils.

During normal loading and unloading operations of the tank, it is possible for the tank bottom to rise and fall slightly. This causes a pressure differential between the exterior and the tank bottom. If there is not an effective seal between the tank bottom and the ring beam it will allow moist air and water to settle between the tank bottom and the cushion. This can lead to localised corrosion on the tank bottom. A flexible seal should be placed around the tank periphery as illustrated by Figure 3. Typically, these seals are proprietary non-crosslinkable polymer compositions or bituminous products.

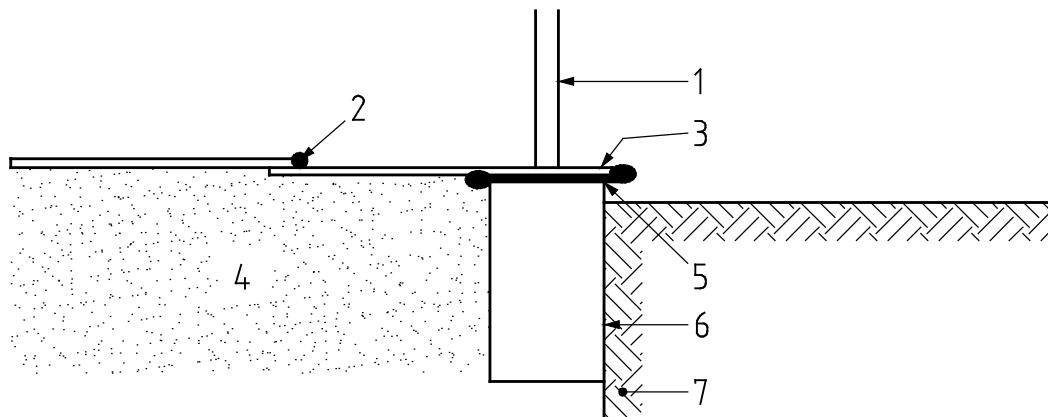

Key

- | | |
|----------------------------------|---------------------------------|
| 1 shell: 20 mm to 40 mm | 5 flexible sealing |
| 2 lap-weld | 6 concrete ring beam with rebar |
| 3 external plate: 10 mm to 12 mm | 7 natural soil |
| 4 sandy cushion | |

Figure 3 — Importance of sealing to prevent water ingress

7.2.3 Bottom external coatings

To reduce the levels of cathodic protection current the tank bottom plates can be externally coated. Regardless of any coatings applied to protect against atmospheric corrosion during transit and storage, the plates should have a qualified coating applied before their installation. The coating should be properly specified to suit the installation and operating conditions, particularly temperature, and compatibility with cathodic protection.

7.2.4 New tank with membrane

Plastic membranes are often installed to contain leaks. The membrane will also electrically isolate the tank bottom from the ground, which has the advantage of preventing external galvanic couples but has the disadvantage of restricting the space available for the cathodic protection anodes and references electrodes or other monitoring systems.

The anode system shall be installed between the membrane and the bottom of the tank as shown by Figure 4. Any other solution will not work.

A minimum distance between the tank bottom and the membrane shall be maintained in order to allow proper and reliable installation of the cathodic protection anode and monitoring systems.

NOTE A typical distance between tank bottom and membrane is 600 mm.

Any kind of metals for earthing system may be used because there is no risk of galvanic coupling.

7.2.5 New tank without membrane

Whenever possible, the tank should be electrically isolated from the plant earthing system and pipework to minimise the current consumption and ensure efficiency of cathodic protection.

If it is not possible, earthing with metals and alloys more cathodic than steel, such as copper or stainless steels, should not be used. Alternative earthing materials such as galvanised steel or zinc should be selected that fulfil the safety requirements and do not create detrimental galvanic couples.

Where earthing systems made of metals and alloys more cathodic than steel are used, the adverse effect of the directly connected earthing systems can be overcome either by an increase of the cathodic protection current (typically the current will need to be at least doubled) or by connecting to the tank via a d.c. decoupling device such as a polarisation cell. Polarisation cells do not impede the flow of alternating current but they block direct current and therefore have no adverse effect on the electrical safety and lightning protection provisions. A local earthing may be used in order to reduce the cathodic current demand.

Care should be exercised when applying isolation in this manner to ensure that the isolation integrity is not compromised by instrumentation earths or inadvertent short circuiting of the isolation by other pipework. In a large plant the complexities are such that it may not be possible to achieve electrical isolation.

The installation of electrical equipment (e.g. pumps, electrically controlled valves, telemetric measuring devices...) in contact with the tank to be protected can affect the electrical separation between this tank and the general earthing system.

Depending on national regulations, separation can be achieved by:

- a) the isolation of electrical equipment from the cathodically protected structure. In this case the equipment is not protected by the cathodic protection system of the tank;
- b) the use of electrical equipment of protection classes II or III defined in EN 61140;
- c) the installation of a fault current breaker, if necessary in conjunction with a local earthing system;
- d) the use of an isolating transformer (safe isolation, see EN 61558-1);
- e) the installation of d.c. decoupling devices between the electrical equipment and the general earthing system.

Where isolation devices are to be used they shall be fully specified within the design both in terms of performance and location. Typical devices include polarisation cells (or any electronic equivalent), surge divertors, lightning arrestors, and insulated flange kits. These should be installed in such a way that accidental contacts of the isolated parts of the structure to the general earthing systems are avoided. They have to be protected against damage caused by atmospheric and mechanical influences.

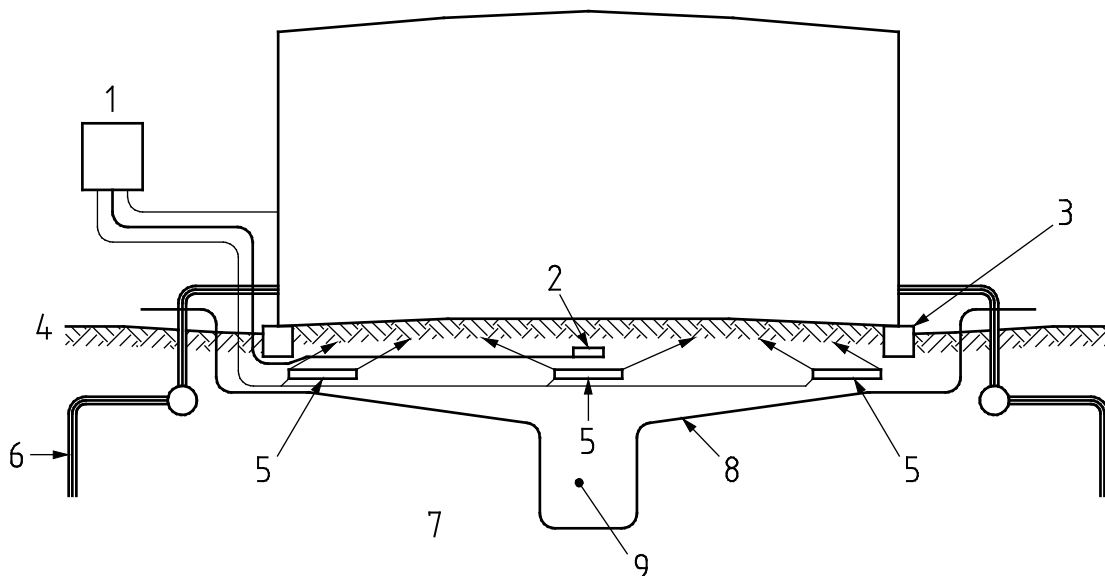

Key

- | | |
|-----------------------|--------------------|
| 1 rectifier | 6 earthing system |
| 2 reference electrode | 7 wet soil |
| 3 concrete ring beam | 8 plastic membrane |
| 4 soil | 9 sump |
| 5 anode | |

Figure 4 — Cathodic protection applied in conjunction with the use of a plastic membrane

If any electrical isolation is installed between the storage tank and the piping, it shall be compatible with:

- national applicable regulations,
- general safety requirements in accordance with codes and standards.

In addition, all isolating joints, whether monobloc or flanges, shall be fitted with lightning protection devices to protect them from damage by high voltage.

All isolating joints should preferably be installed above ground and, for measurement purposes, should be easily accessible from both sides. If buried, they shall be coated.

The requirements for isolating joints in hazardous areas are given in 9.9.3.

The anode system necessary to protect the tank may be installed under the bottom of the tank. Remote anodes can work if properly designed, particularly with respect to the earthing system and piping systems connected to the tank.

7.3 Existing tanks

7.3.1 Extent of corrosion

Cathodic protection and repair strategies should be developed from Information on the degree and location of tank-bottom corrosion.

Field procedures for determining the extent of existing corrosion can include:

- a) visual inspection, sampling of removed bottom plate;

- b) tank bottom plate-thickness measurements (local ultrasonic testing, bottom plate scanning inspection tools using magnetic or ultrasonic techniques, etc.);
- c) location of active corrosion and leaks through the use of acoustic emission techniques;
- d) determination of the magnitude and direction of galvanic or stray current transferred to or from the tank through piping and other interconnections;
- e) estimation of the degree of corrosion deterioration based on comparison with data from similar facilities subjected to similar conditions.

Foundation characteristics are also important factors in the assessment of the extent of existing corrosion. The pad material of construction, thickness of ringwalls, and water drainage should all be considered.

Information should be obtained to permit reasonable engineering judgments. If appropriate, statistical procedures should be used in the analysis.

7.3.2 Electrical isolation

Electrical isolation facilities shall be compatible with electrical earthing requirements conforming to applicable codes and safety requirements. If the tank bottom is to be cathodically protected, the use of alternative electrical earthing materials, such as galvanised steel and galvanic anodes, shall be considered. Alternatively, a local earthing system may be used in order to reduce the cathodic current demand. In this case, it shall be checked that no short-circuit exists with other structures in contact with the general earthing circuit system or other local earthing systems.

The designer of a cathodic protection system should consider the possible need for electrical isolation of the tank from piping and other interconnecting structures. Isolation may be necessary for effective cathodic protection or safety considerations.

Electrical isolation of interconnecting piping can be accomplished through the use of isolating flanges, dielectric bushings or unions, or other devices specifically designed for this purpose. These devices shall be rated for the proper operating pressure and be compatible with the products being transported.

Polarisation cells, lightning arrestors, grounding cells, and other decoupling devices may be useful in some situations for maintaining isolation under normal operating conditions and providing protection for an isolating device during lightning strikes, power surges, and other abnormal situations.

7.3.3 Secondary steel bottoms

The problem of corroded tank bottoms are sometimes overcome by installing a new steel tank floor above the existing, corroded, tank bottom. In such cases, it is not possible to achieve cathodic protection of the bottom of the new floor unless the void between the original and the secondary bottom is filled with an electrolyte, such as clean sand, and a cathodic protection system installed between the two bottoms. Figure 5 illustrates such a system. It does not show permanent reference electrodes, which are necessary to monitor the effectiveness of cathodic protection.

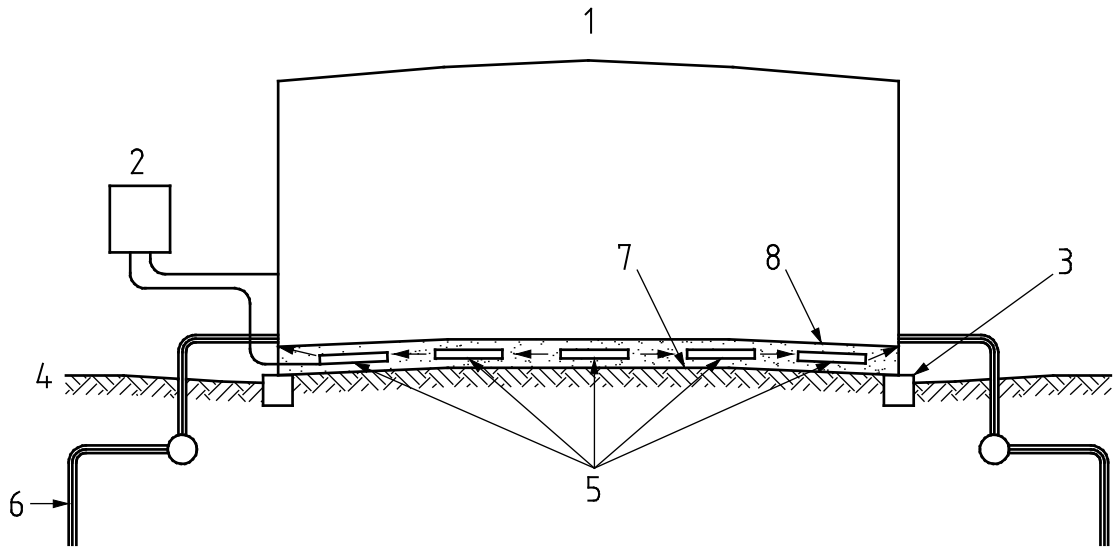

Key

- | | |
|--|-------------------|
| 1 overground tank cathodic protection with rectifiers and anodes | 5 anodes |
| 2 rectifier | 6 earthing system |
| 3 concrete ring beam | 7 old steel floor |
| 4 soil | 8 new steel floor |

Figure 5 — Cathodic protection applied to a secondary steel bottom

7.4 Tank design and feasibility of cathodic protection

The feasibility of installing a cathodic protection system for protecting the external side of tank bottoms is summarised in Table 1 for new tanks and Table 2 for existing tanks.

Table 1 — Tank design and cathodic protection feasibility – New tanks

Tank design	Feasibility of cathodic protection
Membrane under bottom with sand cushion, with or without connection to earthing systems	Feasible if minimum distance between membrane and bottom observed, excellent conditions for ensuring effectiveness of protection.
No membrane, with clean sand cushion, no direct connection to earthing systems	Feasible, excellent conditions for ensuring effectiveness of protection.
No membrane, with any kind of cushion other than clean sand, no direct connection to earthing systems	Feasible, but effectiveness depends on type and quality of cushion.
No membrane, connection to an earthing system	Feasible, but effectiveness depends on type and quality of cushion with higher current demand to apply.

Table 2 — Tank design and cathodic protection feasibility – Existing tanks

Tank design	Feasibility of cathodic protection
Membrane under bottom with sand cushion, with or without connection to earthing systems	Not feasible.
No membrane, with clean sand cushion, no direct connection to earthing systems	Feasible excellent conditions for ensuring effectiveness of protection.
No membrane, with any kind of cushion other than clean sand, no direct connection to earthing systems	Feasible, but effectiveness depends of type and quality of cushion. Especially questionable where soil or cushion contain oily materials.
No membrane, connection to an earthing system	Feasible, but effectiveness depends on type and quality of cushion with higher current demand to apply. Especially questionable where soil or cushion contain oily materials.
Secondary steel tank bottom	Feasible only if design adapted to ensure protection in the void between the old and new bottoms

8 Criteria for cathodic protection and measurement techniques

8.1 General

For any new tank, effectiveness of cathodic protection shall be demonstrated in accordance with the criteria specified in 8.2.

For existing tanks, effectiveness should be verified in accordance with the criteria specified in 8.2 whenever possible. If this is not possible because of contact with other buried structures or earthing systems, alternative criteria and methods as defined in 8.3 are acceptable.

8.2 Criteria

8.2.1 Primary criteria

The metal to electrolyte potential at which the corrosion rate is < 0,01 mm per year is the protection potential, E_p . This corrosion rate is sufficiently low so that during the design life time unacceptable levels of corrosion damage cannot occur on the structure. The criterion for cathodic protection is therefore:

$$E \leq E_p$$

The most common protection potentials (E_p) for above ground storage tank bottom protection are given in Table 3. The criterion is to be chosen according to the resistivity and the temperature of the medium beneath the tank, and to the possible presence of water and aeration conditions. The free corrosion potential (E_{cor}) measurement can sometimes be a guide to determine what kind of conditions are existing below the tank.

The criterion selected is also dependent on the type of the tank and the type of the cathodic protection system. For instance, the cushion beneath a tank constructed with an impermeable membrane and protected from a groundbed using noble anodes (for example titanium - mixed metal oxides) can be in aerobic conditions due to the electrochemical production of oxygen in the presence of water.

Most often, the free corrosion potential cannot be easily defined due to the uncertainties of the actual cushion conditions after the tank bottom has been laid. They can range between – 0,2 and – 0,8 V. In this case, the protection potential for above-ground storage tank bottoms is accepted as – 0,85 V. The potential values are

IR free potentials. Due care should be taken to ensure that the effects of equalising currents and galvanic couples between the tank bottom and the earthing system are taken into account.

Table 3 — Free corrosion potentials and protection potentials for above ground storage steel tank bottoms (measured against copper/saturated copper sulphate reference electrode)

Environmental conditions under tank bottom		Free corrosion potential: E_{cor} (without cell formation) Indicative value (V)	Protection potential: E_p (V)
aerobic conditions	Normal condition $T < 40\text{ }^{\circ}\text{C}$	-0,65 to -0,40	-0,85
	$T > 60\text{ }^{\circ}\text{C}$	-0,80 to -0,50	-0,95
	Aerated sandy soil $100 < \rho < 1\ 000\ \Omega\cdot\text{m}$	-0,50 to -0,30	-0,75
	Aerated sandy soil $\rho > 1\ 000\ \Omega\cdot\text{m}$	-0,40 to -0,20	-0,65
anaerobic conditions		-0,80 to -0,65	-0,95
All potentials are IR free.			
During the lifetime of the structure any possible changes of resistivity of the medium under the structure shall be taken into account.			

8.2.2 Measurement methods

The classical method to measure the IR free potentials is installing an ON/OFF cyclic interrupter in the rectifier(s).

Another method which permits measurements of the IR free potentials without the interruption of the current of the rectifier is using coupons (see 8.2.3).

8.2.3 Coupon IR free potential measurement

A coupon is a piece of bare metal that simulates a coating defect on the tank bottom. During construction it is placed beneath the tank at selected locations (typically near the centre, half way to the periphery and close to the periphery) and close to a permanent reference electrode. The cables from the coupon and reference electrode are terminated at a convenient measuring location outside the bund wall, usually at the transformer-rectifier. Under normal operating conditions the coupon is connected to the tank so that it is experiencing the same electrical conditions as the tank. A switch biased to the ON position can be momentarily depressed to provide an instantaneous OFF (IR free) coupon potential.

8.3 Alternative criteria and methods

8.3.1 General

The criteria given in Table 3 should be used wherever possible.

If the tank is not electrically isolated from any earthing system through decoupling devices, it is a complex structure (see EN 14505). This can lead to difficulties in the interpretation of potentials measured using permanent reference electrodes placed beneath the tank bottom or portable electrodes placed near the tank periphery. The following alternative methods of verification of the cathodic protection effectiveness, and the reduction of the corrosion rate, can be used:

- coupon current density measurements; this depends upon a coupon being installed beneath the tank at the time of construction;
- peripheral potential measurements with a calculation to determine the potential gradient beneath the tank bottom (see 8.3.3);
- a cathodic shift (polarisation) of 0,1 V from the unpolarised tank bottom, in the absence of galvanic couples that could adversely affect the accuracy of the measurements;
- a positive shift (depolarisation) on test probes or coupons of at least 0,1 V measured from immediately after disconnection (E_{off}) to 1 h after disconnection from the structure to indicate that the structure is polarised; these test probes/coupons are disconnected only for measurements;
- electrical resistance corrosion probes; this depends upon the probe being installed beneath the tank at the time of construction. These probes will have a finite life if the cathodic protection is not effective.

8.3.2 Coupon current density measurements

The current flowing to and from the coupon can be measured and the current density calculated. The current density value can be compared to the design value of cathodic protection current density required to achieve cathodic protection.

8.3.3 Peripheral potential measurements

When the cathodic protection anodic system is installed outside the periphery of the tank bottom and in the absence of permanent reference electrodes beneath the tank bottom, the only possibility is to measure the potential at the tank periphery and estimate the potential under the tank bottom at various locations by calculation [5].

A calculation method to establish the mapping of potentials under the tank bottom uses modelling software and polarisation curves.

Measurement of the potential at the tank periphery can be difficult due to the ring beam and possibly the ground conditions. In such cases the optimum location should be selected and a permanent facility for the placement of a portable reference electrode provided.

8.3.4 Electrical resistance probes

Electrical resistance probes allow the corrosion rate to be calculated by accurate measurement of the increase of the probe resistance over time. The selection of the size of the probe element, and hence its longevity, also affects the resolution of the probe with respect to rapid changes in the corrosion rate. These probes have to be installed beneath the tank bottom at the time of construction.

A calculated corrosion rate less than 0,01 mm/yr when the electrical resistance probe is connected to the tank with cathodic protection applied demonstrates a complete effectiveness of protection. Higher corrosion rates may be acceptable provided they are compatible with the design life of the tank.

9 Design of cathodic protection systems

9.1 General

Pre-requisites for carrying out the design of an efficient cathodic protection system as detailed in Clause 7.

Because of the practical difficulties in retro-fitting of the anodes the design of the cathodic protection system for a tank bottom should be based on a pessimistic coating performance and anode consumption hypothesis.

The design of effective cathodic protection systems is dependent upon correct information concerning the tank to be protected and its environment. It is essential to know the design limits and especially the location of all the isolating devices and/or earthing systems. Structures, soil conditions and the selected lifetime for the cathodic protection system need to be known to establish the correct method of protection and to adopt the correct materials to achieve and sustain effective cathodic protection.

9.2 Structure details and data

9.2.1 General

Whether the tank to be protected is new or existing, cathodic protection design requires knowing the following information together with results gathered during field tests.

9.2.2 Location

- Site map with the precise location and the general drawing of the tank and associated piping.

9.2.3 Tank design

- Date of construction in the case of existing structure;
- Type (including physical and chemical characteristics) and temperature of the stored liquid;
- Detailed drawing of the tank including dimensions, number and location of wall entries, manholes, sleeve-pipes and pits, etc;
- Structure materials, welding and coating specifications;
- Description of previous cathodic protection system, if any, and history of protection measurements;
- Power availability;
- Presence of secondary bottom, if any;
- Detailed nature of the foundation and cushion (construction and materials);
- Containment membranes / impervious linings;
- Measurement of tank to soil potentials over an extended period of time (typically 48 h) using a data logger for existing tanks.

9.2.4 Safety data

- Detailed data concerning electrical equipment connected to the structure;
- Drawing of the hazardous areas with their classification;
- Detailed electrical earthing systems including specifications and drawings;
- Location and details of all the isolating devices (isolating joints to be selected with due consideration of the stored liquid e.g. chemical nature, corrosivity, conductivity, pressure, temperature, etc.);
- Containment membranes / impervious linings if any.

9.3 Environment

9.3.1 General

The environment can have a major impact on the application and efficiency of cathodic protection and consequently need to be carefully studied during the design phase.

9.3.2 Native surrounding soil

- Possible soil pollution, water table, site draining, etc;
- Soil resistivity, which should be measured at various locations and depths and on the cushion that will be actually in immediate contact with the tank bottom. If remote anodes are to be utilised then knowledge of the soil resistivity at the proposed anode locations and depth is necessary;
- Likelihood of sulphate reducing bacteria development;
- Determination of the presence and magnitude stray currents transferred to or from the tank through piping and other possible interconnections;
- Possible galvanic effects in the case of widely dispersed structures due to differences in environmental conditions.

9.3.3 Cushion

The quality and composition of the tank cushion has a major effect on the performance and effectiveness of the designed cathodic protection system (see 6.2.2 and 7.2.1).

9.3.4 Neighbouring structures

Details of nearby foreign structures such as pipes or tanks, buried or laid on the soil, should be obtained. The use of such information can help to prevent adverse effects on the structure and on neighbouring structures. It should include as a minimum:

- location and characteristics (e.g. maps, detailed site layout) with regard to the structure to be protected;
- coating details;
- type and location of any earthing system;
- type and location of isolating devices;
- details of any other cathodic protection system;
- any other possible sources of stray current;
- measurement of stray current flow and direction in the connected pipes for existing tanks.

9.4 Electrical isolation

It is preferable that the tank is electrically isolated from the plant earthing system and pipework to minimise the cathodic protection current requirements, and hence the risk of interference to adjacent structures. This can be achieved by the use of a local earthing system or of a dielectric membrane installed beneath the tank. In such a case the anode system will be installed between the dielectric membrane and the tank bottom.

In some circumstances it is possible to provide electrical isolation from the earthing system by interposing a solid state polarisation cell between the tank and the earthing system and from the pipework by the use of insulated flanges.

Where electrical isolation is not possible, for example where the cathodic protection system is to be retrospectively installed, due account should be taken of a significant current drain to the low resistance earthing system. It can be assumed that more than 90 % of the cathodic protection current intended for the tank bottom will go to the earthing system. The tank anode and transformer-rectifier capacity should take account of this.

9.5 Current requirements

Current requirements can be determined by calculating the surface area of the tank bottom that will be in contact with the ground and applying the required current density. The applied current density should take into account the coating and the cushion conditions towards the end of life. A minimum value of 5 mA/m² may be used for coated tank bottoms when no specific data are available.

If there is any risk of stray currents affecting the structure then tests should be carried out to determine the extent and magnitude of the stray currents so that the design current requirements can be increased to offset the effects of the stray currents. Sources of stray current can include d.c. traction systems such as railways, high voltage d.c. cables, and industrial dc systems.

If there is no dielectric membrane, or other form of effective electrical isolation, then an allowance should be made for cathodic protection current that will flow to the other structures and to the earthing system (see 9.4).

If the anodes are intended to be placed remote from the tank then a current injection test can be carried out to empirically determine the level of current required to achieve cathodic protection.

9.6 Cathodic protection systems and anode configuration

Depending upon the size of the tank, the cathodic protection current requirements, soil resistivities and the design lifetime it may be possible to use galvanic anodes to provide cathodic protection. Anodes may be placed in the soil directly beneath the tank or buried below the ring beam around the tank periphery. When a containment membrane is used, the anode system shall be installed between the membrane and the bottom of the tank.

If impressed current anodes are to be used, then there are two basic options. The anodes can be either installed in the soil beneath the tank or external to the tank. If the anodes can be installed in the soil beneath the tank then it is preferable to use a grid or concentric ring configuration. This provides better current distribution and, since it is physically close to the tank bottom, the current requirements will be lower and the risks of interference reduced.

If the impressed current anodes are intended to protect the new bottom of an existing tank, which has had its initial bottom corroded and has been repaired with a new steel bottom installed over the old one (see 7.3.3), the anode system shall be installed in the void between the two bottoms.

In cases where the anodes are to be installed external to the tank, for example where the cathodic protection system is being retrofitted or upgraded, then it is recommended that the anodes are installed vertically around the tank periphery and at a depth that will ensure that the ring beam will not impede the current flow and the current will reach all areas of the tank bottom. A method of calculation is proposed in [5].

9.7 Cable connections to the tank

Structure connections to the tank shall be made to a lug or fitting on the tank rim. For the purposes of redundancy there should be at least two connections. The connections may be either directly brazed or securely bolted. The connections shall be clearly labelled and identified as cathodic protection connections and protected from environmental corrosion by the application of a qualified protective coating.

9.8 Reference electrodes, coupons and test stations

Reference electrodes and coupons shall be considered in the design (see EN 13509).

The electrodes should be of a construction and type providing reliable measurements throughout the design lifetime of the tank, especially at the temperature of the environment where they are located. The contamination of their electrolyte with foreign media coming through the soil should be avoided.

Coupons should be placed adjacent to some of the reference electrodes to allow potential measurements with minimal errors caused by current flowing in the soil. Coupons will also allow the current flowing to a known surface area to be measured and hence for the current density to be calculated. This current density value can be used to verify that the design current density criterion is being met.

The design shall ensure that the tank to reference electrode potentials, coupon to reference electrode potentials, and coupon current densities can be easily measured at a transformer-rectifier or monitoring box outside the tank bund wall. Facilities shall be provided to enable simple disconnection of the coupon from the tank during the coupon measurements.

Permanent reference electrodes, with or without coupons, shall be installed under the tank bottom during construction or installation of a secondary tank bottom.

Permanent reference electrodes may be positioned inside an access piping (see 10.6).

NOTE Absence of permanent reference electrodes in the case of a dielectric membrane or secondary bottom prevents any verification of the effectiveness of cathodic protection.

The minimum number of permanent reference electrodes (and coupons) can be decided based on the following recommendation:

- one measuring point for each tank;
- two measuring points for each tank with a diameter of more than 10 m and less than 25 m;
- one additional measuring point for every 20 m above 25 m.

Facilities shall be provided to enable the measurement of the ON and OFF potentials of the tank with respect to each reference electrode as well coupon potentials and currents. Where the cathodic protection currents are low (e.g. less than 5A) OFF potentials can conveniently be measured by momentarily interrupting the cathodic protection current by a spring loaded switch.

If there are no permanent reference electrodes beneath the tank then portable reference electrodes can be used at various locations around the tank periphery. Due to the difficulties of consistent soil connection for the reference electrode permanent measuring facilities shall be installed around the tank periphery. These can consist of a non-metallic pipe filled with native soil that penetrates any concrete or other impervious layers around the tank. The measuring facilities shall be clearly identified, circumferentially equidistant, and fitted with an easily removable cap to prevent the ingress of unwanted moisture and contaminants. If feasible, the measurement facility shall penetrate through the ring beam to obtain potentials of the inside peripheral plate.

Calculations can be carried out to estimate the potential at any point beneath the tank based on the peripheral measurements (see 8.3.3).

For measurement purposes, all isolating joints should be easily accessible from both sides. If they are not accessible, they shall be provided with a test station.

9.9 Explosion hazard prevention

9.9.1 General

Cathodic protection equipment and its installation in explosive gas atmospheres shall conform to the classification of the hazardous areas (zones 0, 1 and 2) in accordance with EN 60079-10-1.

9.9.2 Electrical equipment installation

Any equipment installed shall comply with the equipment protection levels specified in EN 60079-14.

Installation of electrical equipment in zone 0 should be avoided. For this reason cathodic protection junction boxes, transformer-rectifiers and monitoring facilities should be placed in non hazardous areas (e.g. outside the bund wall).

If installed in zone 0, it is essential that the equipment, including monitoring facilities, conforms to EN 60079-11 and that it is of type i_a .

In zone 1, it is essential that explosion-proof electrical equipment or systems conforming to one of the following standards are used:

- EN 60079-11, Intrinsic safety type 'ib';
- EN 60079-1, Flame-proof enclosure type 'd';
- EN 60079-5, powder filling type 'q';
- EN 60079-2, Pressurisation type 'px' ou 'py';
- EN 60079-7, Increased safety type 'e';
- EN 60079-18, Enclosure type 'mb';
- EN 60079-25, Intrinsically safe system type 'SYST'.

In zone 2, the equipment shall comply with requirements of EN 60079-15 dealing with "Non sparking type 'n'".

9.9.3 Isolating joints

Isolating joints between cathodically protected and non-protected parts of the installation should not be placed in hazardous areas.

The design shall be such that accidental bonding is not possible.

Isolating joints shall be designed for electrical, mechanical and chemical operating conditions and before installation be able to withstand a testing alternating voltage of 5 kV according to EN 60587 over a period of one minute.

Depending on local regulations, installation of isolating joints may not be permitted in zone 0 and accepted in zones 1 and 2 provided they meet the requirements applicable to these zones as defined in 9.9.2.

Explosion-proof spark gaps should be installed at isolating joints in zones 1 and 2 to avoid sparks or flashover.

9.10 Galvanic anode systems

9.10.1 General

Cathodic protection using galvanic anodes can be obtained economically if:

- the size of the tank is small;
- the current requirement is low;
- the soil has a low resistivity.

Galvanic anodes are usually installed in a low-resistivity and non-carbonaceous backfill.

To meet the cathodic protection criteria, the following should be considered:

- use of an efficient protective coating on the tank bottom;
- maintain a good isolation between the structure to be protected and the neighbouring structures;
- avoid the use of bare buried wires (e.g. for making connections to the earthing system).

9.10.2 Materials

Galvanic anode materials shall be magnesium or zinc.

Zinc anodes have a lower capacity and a smaller driving voltage against carbon steel than magnesium anodes.

The choice between magnesium and zinc also depends on design life requirements and economic considerations.

9.10.3 Location

The location of the galvanic anodes depends on the structure to soil resistance and should be selected such that the desired current distribution can be achieved.

Installation of galvanic anodes under tank bottoms is not recommended, especially in presence of a membrane.

9.10.4 Connection of anodes to the structure

To check the efficiency of the galvanic anode system, it shall be connected to the structure via a test station.

For functional checks, each anode should be connected separately to the test station.

9.11 Impressed current systems

9.11.1 General

Impressed current cathodic protection is generally recommended, especially for large tanks and where there are high resistivities of the soil and cushion.

9.11.2 Anode materials

Anode materials commonly used are:

- silicon iron alloys;
- titanium covered with mixed metallic oxides;
- conductive polymers;
- graphite;
- magnetite.

The selection of the anode material depends on the individual application (see Annex A).

9.11.3 Transformer-rectifiers

The transformer-rectifiers shall be rated for the anticipated current output until the end of the chosen design lifetime of the cathodic protection system and in accordance with safety rules (see EN 61558-1) and operating conditions (see EN 60079-0).

The transformer-rectifier specification should take into account the monitoring requirements (e.g. permanent reference electrodes and coupons, ON/OFF measurements, output control) and the location.

9.11.4 Groundbeds

For anode ground beds which are not installed beneath the tank, the number, size and position of the anodes and the extent of the groundbeds should be selected so that:

- they correspond to the chosen design lifetime for the cathodic protection system;
- the desired current distribution can be achieved without adverse interference to foreign structures.

Annex A gives information for deep well and shallow groundbeds located remote from the tank.

The anodes should be placed in a low resistivity backfill, e.g. electrically conductive carbonaceous backfill.

The distance between the anodes and foreign structures depends on the driving voltage and the soil resistivity, but should be at least 2 m.

9.12 Cables

Insulated cables shall be used.

NOTE Double-insulated cables are generally used to prevent mechanical damage especially for anode systems installed under the tank bottom.

Minimum cable cross sections should be as follows:

a) impressed current system:

- 1) cable to protected structure: 10 mm² Cu;
- 2) cable to groundbed: 4 x 2,5 mm² or 10 mm² Cu;

b) galvanic anode system:

- 1) cable to protected structure: 4 mm² Cu;
- 2) cable to single anode: 2,5 mm² Cu;

c) test station:

- 1) cable for potential measurement: $2 \times 2,5 \text{ mm}^2$ or 6 mm^2 Cu;
- 2) cable for continuity bond : $4 \times 2,5 \text{ mm}^2$ or 10 mm^2 Cu.

In general, the cable size will be determined by the permissible IR drop in the specific cable run. However, where current requirements are very small, selection of the conductor cross section may be based upon mechanical strength rather than electrical resistance.

Therefore, cables with smaller cross sections than those recommended can be used if the cables and their connections have sufficient mechanical protection.

9.13 Interference

Any possible interference to the tank bottom to be protected will depend on the size of the tank and the proximity of possible sources of stray current, e.g. d.c. traction systems, neighbouring cathodic protection systems. The adverse effects of stray d.c. current interference and measures to reduce this interference are detailed in EN 50162.

The level of interference to foreign structures caused by a cathodically protected tank will depend mainly on the output current of the anodes and on the distance between the anodes and the foreign structures. To minimise the risk of interference on foreign structures, one or more of the following measures should be taken:

- the rectifier output voltage and the anode current output should be minimised;
- the distance between the foreign structure and the nearest anode should be increased.

NOTE Anodes installed between a tank bottom and a membrane do not cause interference to foreign structures.

10 Installation of cathodic protection systems

10.1 General

This clause concerns the main aspects that should be considered during the installation of cathodic protection components for above ground carbon steel storage tank bottoms.

The installation of cathodic protection systems should be under the supervision of trained and qualified personnel (see Clause 5) to ensure that the installation is made in strict accordance with the drawings and specifications. Exceptions can be made only with the approval of the owner, operator, or personnel representing them.

Installation of the cathodic protection system shall be carried out in accordance with the design based on the prerequisites detailed in Clause 7. This includes the location and installation of test stations and galvanic anodes or impressed current systems.

The other equipment determined by the design, such as isolating joints, coatings, and local earthing devices, are integral parts of the structure to be protected and are therefore installed at the same time as the main structure to be protected.

The cathodic protection system should be installed as soon as possible, preferably during the installation of the tank. In some cases the anodes, reference electrodes, coupons and cables are located under the tank bottom and shall be installed prior to the laying of the tank bottom.

The following points shall be considered:

- a) before the beginning of the work, it shall be verified that:

- 1) the equipment and the materials to be installed are in conformity with those indicated in the design;
 - 2) particular attention has been paid to the location and extent of any sumps and drainage pipes beneath the tank bottom that could come into contact with the anodes;
 - 3) the local conditions are the same as those used for the design;
- b) during the work, it is necessary to verify that the installation and materials are in conformity with the appropriate regulations, including safety;
 - c) any deviations from the design shall be documented and reported on the as-built documentation for approval;
 - d) the explosion hazard prevention measures mentioned in 9.9 should be taken.

If there is a risk that tanks may come into metallic contact with other structures (e.g. reinforcing steel, anchors) it is recommended that permanent electrical isolation is ensured before backfilling.

10.2 Installation of cables

10.2.1 General

In all cathodic protection installations cables shall be installed with great care to avoid damage to the insulation. They should be run through non conductive ducts and be protected with a minimum depth of cover (e.g. 80 cm) and have warning tapes.

If cables in ducts pass through hazardous areas, the ducts shall be sealed to prevent flammable liquids and gases from being carried into non-hazardous areas.

As far as possible cable joints in the ground should be avoided.

Cable should be long enough to accommodate any ground settlement.

All cables should be run to above-ground junction boxes preferably installed outside hazardous areas. Junction boxes in hazardous areas e.g. valve pits and dome shafts should be flameproof.

The cables shall be clearly identified, either by using different colours, or by identification marks.

There should be some slack in the anode lead wires to avoid possible damage due to settlement of the tank and surrounding soils. Anodes, lead wires, and connections should be handled with care to prevent damage or breakage.

The anode lead wires should be extended to the side of the tank away from the construction to minimise possible damage. After the tank foundation has been prepared and the tank set in place, the wires should be terminated in a test station or junction box, which may include shunts for measuring anode current outputs.

NOTE Attention is drawn to the electrical and safety regulations governing cables.

10.2.2 Cable connections to structures

Cables bonding different parts of the structure to be protected should be accessible and allow disconnection. Cable connections to foreign structures shall be agreed with the owners of those structures.

The cables should be connected to the structure at points where they are unlikely to be damaged during operation or maintenance.

Cable connections to the structure to be protected should be made by welding, thermit welding, brazing, bolts or conductive adhesives (the latter only for measuring cables) and shall be protected against corrosion (e.g.

by coating). For screwed connections and cable lugs, bolts of at least size M8 which are protected against self-loosening shall be used. All cable connections shall be low resistance.

The cable connecting procedure used should be such that it does not affect the mechanical properties of the structure.

It is recommended that conductors used for measuring purposes be kept separate from those carrying protection current.

10.3 Isolating joints

To allow inspection, isolating joints, particularly of the insulated flange type, should preferably not be buried. However, joints of all types, when buried, shall be coated with materials compatible with the structure coating and shall be fitted with test cables.

NOTE Above-ground isolating joints installed in hazardous areas are covered by national safety regulations, which require special safety measures to be taken, e.g. the application of a protective coating to prevent accidental contact and the fitting of explosion-proof spark gaps to prevent flashover.

10.4 Anodes

10.4.1 Galvanic anodes

At the time of installation of galvanic anodes, checks should be carried out to ascertain, by reference to the design file (plans, specifications and procedures) whether or not the following points are covered:

- the electrolyte condition and resistivity where the anodes are to be located corresponds to the design;
- there is no isolating shielding between the anode and the structure to be protected;
- anodes conform to the specifications;
- the anode backfill material used is the correct type for the anodes concerned, and that the homogeneous backfill mixture is evenly distributed around the anode (minimum 50 mm);
- the pre-packaged anodes have been thoroughly wetted before burial;
- the electrical circuit between the anode and the structure has been left open at the test station until the commissioning (see Clause 11).

Where a ribbon-type anode is used under tank bottoms, it is generally installed in clean, dry sand without special backfill. Ribbons should be carefully straightened and made to lie flat so that the anode will not contact the steel bottom.

10.4.2 Impressed current anodes

At the time of installation checks should be carried out to ascertain, by reference to the design file (plans, specifications and procedures), whether or not the following points are covered:

- the electrolyte condition and resistivity where the anodes are to be placed correspond to the design;
- there is no isolating shielding between the anodes and the structure to be protected;
- there is no risk of interference to other buried or immersed metal structures from the anodes; if there is a risk, then corrective measures have been taken.

The dimensions of the anodic mass of the groundbed should be checked to see if they correspond to those indicated in the design. The backfill, if any, should be checked to verify that it is in conformance and that it has been correctly prepared. It is particularly important to check that the backfill is both sufficient in quantity and homogeneous, and meets the requirements of the project specification.

The integrity of the insulation of the cable connection between the groundbed (or an element of the groundbed) and the impressed current station is essential. If not, moisture ingress and subsequent oxidation of the conductor, can lead to the premature failure of the groundbed.

The electrical circuit between the groundbed and the structure, through the transformer-rectifier, should be left open at the transformer-rectifier until the commissioning period.

10.5 Impressed current stations

10.5.1 Location

The impressed current stations should be easily accessible and protected against the effects of the environment and mechanical damage. They should be located outside hazardous areas or, alternatively, be of a type specified for use in such areas (see 9.9.2).

10.5.2 Electrical installation

The electrical equipment and its installation should be designed for continuous operation and, where appropriate, fitted with a visual indicator to show that it is operational.

10.6 Test stations, measuring points, permanent reference electrodes, and coupons

Test stations should be located in easily accessible places, protected against the risk of mechanical and electrical damage (e.g. shocks). They should preferably be located outside hazardous areas (see 9.9.2).

The number and location of fixed measuring points, permanent reference electrodes and coupons shall be verified according to the design.

Permanent reference electrodes, or non-conductive, perforated tubes for temporary installation of a portable reference electrode, should be installed under all tanks regardless of the groundbed type and location.

Permanent reference electrodes may be pre-packaged in a backfill and placed in the soil under the tank bottom or positioned inside the perforated reference electrode access piping. Reference electrodes placed inside access piping should be surrounded with a backfill material designed to provide contact between the electrode and the electrolyte outside the pipe. If practical, provisions should be made for future verification of all stationary reference electrode potentials with portable reference electrodes.

Reference electrode access piping should have some means of contact with the electrolyte and should have at least one end accessible from outside the tank shell. This contact can be through the use of holes, slits, or not capping the end of the piping beneath the tank. Perforations and slots should be designed to minimise entry of tank pad material. Portable reference electrodes shall be inserted through the inside diameter of the access pipe with a non-metallic material such as small-diameter polyvinyl chloride (PVC) pipe. Inserting a reference electrode with metallic tape, bare wires, etc., may adversely affect potential readings. If necessary, water should be injected inside the access pipe to establish continuity between the electrode and the electrolyte. Deionised water should be used for double-bottom tanks or tanks with secondary containment.

For existing tanks, reference electrode access piping should be installed under the tank with horizontal drilling equipment capable of providing guidance and directional control to prevent tank bottom damage and to ensure accurate placement of the piping. The structural aspects of the tank padding and foundation should ensure that support capabilities are not adversely affected.

10.7 Bonding

Connection devices between cathodically protected tank and foreign structures shall be easily accessible to all concerned parties and should be protected against damage by environmental effects.

10.8 Labelling

For information and safety reasons appropriate labels should be attached to the main components of the systems, such as impressed current stations, test stations and the structure to be protected.

Depending on the place of installation and the type of structure protected, these labels should:

- include safety signs concerning the dangers of electricity;
- include hazardous area signs;
- describe measures to be taken in case of failure;
- give the name of the owner/operator of the system;
- indicate that the cathodic protection system should be continuously energised, unless work is being carried out on the protected structure;
- include circuit diagrams.

All cables within test stations shall be clearly identified.

10.9 Installation checks

During the work it is necessary to verify that the installation and materials are in conformity with the design and appropriate regulations, including safety.

Underground components, including connections, shall be checked before covering with soil.

Deviations from the design shall be justified for approval, then documented and later reported on the as-built documentation.

Checks may include:

- installation of the galvanic anodes;
- installation of the transformer-rectifier (design, anode and cathode cable connections and electric function);
- installation of the groundbed with backfill;
- cable laying, cable connections, cable marking, integrity of cable ducts;
- installation of permanent reference electrodes and coupons;
- installation of fixed measuring points;
- test stations (location, design and marking of measurement sockets).

10.10 As-built documentation

Electrical diagrams and site layout drawings shall be made for the cathodic protection system, showing the tank design, the location and type of galvanic and impressed current anodes, the impressed current stations, test stations and isolating joints as well as nearby foreign structures.

11 Commissioning

11.1 General

Commissioning activities require that all the cathodic protection installations have been correctly installed according to the design and are fully functional.

Commissioning measurements shall be made in accordance with EN 13509 by qualified personnel (see Clause 5) to verify whether criteria specified in Clause 8 are fulfilled.

These measurements should be made when there is sufficient liquid in the tank to ensure that the entire tank bottom is in good contact with the cushion, typically to the height of one shell plate. This can be achieved when the tank is undergoing hydrostatic tests.

When the duration between laying the tank bottom and hydrotesting is considered too long for the soil corrosivity (e.g. 6 months to 12 months), pre-commissioning of the cathodic protection is recommended.

11.2 Preliminary checking

Cable connections and safety measures (contact protection, lightning protection, explosion proofing) where necessary shall be checked.

Cathode connections to the tank should be verified. These should be mechanically and electrically in good condition and should be protected from external corrosion.

Anode junction box cables should be verified as being tight and secure and the junction box should be accessible and in accordance with the design.

Correct polarity at the output terminals of the transformer-rectifier connections should be verified.

Verify the correct installation of all isolation devices (if installed) e.g. insulated flanges, polarisation cells, monobloc isolation joints.

All cables shall be identified and permanently marked to help prevent cabling errors.

After all connections have been verified the following measurements should be made before the application of cathodic protection, and the readings compared with the design requirements:

a) resistance measurements:

- 1) resistance of the tank bottom against remote earth;
- 2) resistance against remote earth of the groundbed or the galvanic anodes;
- 3) resistance between the tank and the groundbed or the galvanic anodes;

b) electrical separation of the structure:

- 1) at isolating joints;

- 2) from the general earthing system;
- c) potential measurements:
 - 1) tank to soil potentials using permanently installed reference electrodes;
 - 2) tank to soil periphery potentials at a minimum of four locations using portable reference electrodes;
 - 3) interference due to suspected stray currents,
 - 4) anode to electrolyte potential of galvanic anodes,
 - 5) structure to soil potentials of adjacent buried structures;
- d) measurement to determine the extent of any interference from, or on, foreign structures.

These values will constitute the baseline measurements and will be used to determine the effectiveness of the applied cathodic protection.

11.3 Start-up

For galvanic systems apply the following commissioning procedure:

- connect all of the anodes;
- measure each anode output current using the technique shown in EN 13509;
- measure the tank to soil ON and IR free potentials using either the permanent reference electrodes or the portable reference electrodes. If portable reference electrodes are used then the same locations that were used for the baseline measurements should be used again;
- when necessary, connect galvanic anodes to the protected structure via a variable resistor for current limitation.

For impressed current systems apply the following commissioning procedure:

- apply power to the transformer rectifier;
- measure ON, OFF and IR free tank to soil and coupon potentials;
- adjust the d.c. current output to achieve cathodic protection in agreement with the potential requirements in the design, at all the selected testing stations and/or selected locations; if major deviations occur, the causes should be ascertained by measurement;
- measure anode current outputs;
- measure structure to soil potentials of adjacent structures that were previously measured and verify that interference levels are acceptable when switching ON and OFF the cathodic protection system of the tank;
- leave the cathodic protection system operating for the time necessary to reach the steady state conditions (at least 24 h, or longer for tanks previously unprotected or uncoated);
- adjust the d.c. current output to maintain cathodic protection and re-measure potentials on adjacent structures;
- if major deviations occur, the causes should be ascertained by measurement.

If d.c. stray currents are present, measurements shall be carried out to determine the interference level in order to adjust the cathodic protection and ensure that it is effective. These measurements shall be made with, and without, the cathodic protection stations in operation.

11.4 Verification of the cathodic protection effectiveness

To verify whether criteria specified in Clause 8 are fulfilled, tank to soil potentials shall be measured when the tank is operational (typically every 24 h) for a minimum period of time covering the operational cycles of the tank. In absence of defined operational cycles the measurements should be carried out over a period of at least 7 d.

Current output shall be adjusted when necessary.

11.5 Determination of relevant measuring points

At the end of the commissioning measuring points that are relevant for further periodic structure measurements may be determined.

11.6 Commissioning documents

After the successful commissioning of the cathodic protection installations, the following shall be prepared:

- as-built drawings of the tank and its geographical position and those of all neighbouring structures likely to be affected by the cathodic protection system (see 9.3.4);
- cathodic protection design with as-built drawings and all details pertaining to the cathodic protection of the structure;
- results of interference tests carried out on neighbouring structures;
- details of equipment operation and adjustment and the results of all measurements carried out before and after commissioning;
- summary of the installation records with references to any materials used and/or installation work that were not covered by the design.

NOTE The final data is the basis for subsequent system checks to be performed on the structure and therefore need to be filed and retained.

12 Inspection and maintenance

12.1 General

The aim of inspection and maintenance is to ensure the effectiveness of cathodic protection throughout the life of the structure. For this to be achieved, the required structure to electrolyte potential shall be maintained within the limits stated in the design by continuous operation and maintenance of the cathodic protection system.

12.2 Inspection

12.2.1 General

Subsequent to commissioning (see Clause 11), regular inspection is necessary according to approved procedures. The procedures should be subject to review to reflect operating experience and new technology.

Instrumentation used for measurements shall be kept in good working order and shall be subject to periodical calibration and safety checks.

Inspection shall comprise:

- functional checks of the cathodic protection equipment;
- measurements for evaluating effectiveness of protection.

The results of measurements and all other findings shall be recorded.

The procedures used and the results obtained shall be reviewed and approved by personnel with the required cathodic protection theoretical and practical knowledge (see Clause 5).

If any abnormalities are observed, the causes shall be investigated and appropriate action shall be taken.

NOTE Attention is drawn to national regulations regarding electrical safety checks.

12.2.2 Functional checks of equipment

Regular visual inspections of the installation (e.g. transformer-rectifier operation, readings of indicators, accessibility of test stations, connections) should be made to check the functioning and the good working conditions of the cathodic protection equipment.

12.2.3 Measurements assessing cathodic protection effectiveness

The cathodic protection effectiveness is assessed by comparing measurement values with the protection criterion or reference values.

Depending on the tank (type, size...) and the cathodic protection system, the following measurements shall be carried out:

- rectifier output voltage of impressed current station;
- protective current;
- ON and OFF potentials at relevant measuring points and coupons;
- ON potential and current requirements of adjacent structures;
- d.c. interference to or from foreign structures, and, if found to be necessary, after modification or readjustment of the cathodic protection system (see EN 50162).

Measurements listed in 11.2 may be also carried out to gather information on changes made to the cathodic protection system. They concern:

- resistance measurements;
- electrical separation of the structures.

If there are indications that the cathodic protection is not fully effective throughout the structure, investigations should be carried out and appropriate corrective action taken to restore effective cathodic protection. The measured values obtained are then used as the new reference values.

12.2.4 Inspection intervals

12.2.4.1 Frequency of equipment functional checks

Functional checks should be carried out at the typical frequencies given by Table 4.

Table 4 — Frequencies of functional checks

Galvanic anode systems	According to the frequency of the verifications of the cathodic protection effectiveness (see 12.2.4.2) or more frequently if required by operational conditions.
Impressed current systems	Every month or more frequently if required by operational conditions depending upon the installation and the reliability of the power supply. Shorter intervals may be necessary for installations where the supply is subject to interruption.
Bonds to adjacent structures	Annually or more frequently if required by operational conditions.
Safety and protection devices	Annually or more frequently if required by operational conditions.
Test facilities	According to the frequency of the potential measurements (see 12.2.4.2) or more frequently if required by operational conditions.

12.2.4.2 Frequency of the verification of the cathodic protection effectiveness

The period of time between two successive assessments of cathodic protection effectiveness is typically one year. Nevertheless, according to the type, design and location of tanks, and the consequences of a leak, this inspection interval may be reduced or increased to a maximum period of time that shall not exceed three years.

A remote monitoring system installed on impressed current systems and test facilities will help to increase the intervals of on-site verification.

The effectiveness of cathodic protection should also be checked when changes are observed in the structure or the environment and in particular after construction work in the vicinity of the structure.

12.2.5 Inspection report

The results of inspections shall be recorded and evaluated.

These records shall be kept for the life of the tank to provide detailed information on the cathodic protection effectiveness and to allow comparative checks to be carried out.

In addition, it is recommended that the records and the cathodic protection history are kept for reference purposes for the lifetime of the structure.

12.3 Maintenance

12.3.1 General

Maintenance should be carried out to ensure the correct operation of the system. In the case of galvanic systems this will be limited to checking that the anode junction box is mechanically and electrically sound and that the anode currents are within the design limits.

For impressed current systems electrical and functional checks should be performed on an annual basis.

12.3.2 Cathodic protection equipment

Routine maintenance shall be carried out to ensure that the cathodic protection system continues to operate in the manner intended by the design.

Transformer rectifiers shall be maintained in accordance with the manufacturer's recommendations.

Maintenance on cathodic protection equipment should also be carried out when necessary during, or as soon as possible after, functional checks or structure measurements.

12.3.3 Instrumentation

Instrumentation (e.g. permanent reference electrodes, measuring and regulating devices) shall be kept in good working order and shall be subjected to periodical calibration and safety checks.

Annex A **(informative)**

Groundbed data

A.1 General considerations

The application of cathodic protection to above ground storage tanks, as described in this standard, usually needs particular configurations of groundbeds. Sometimes a configuration with a remote located groundbed can be used, but to ensure that the cathodic current reaches the desired structure and is not shielded by other buried structures, a close located groundbed is often necessary.

In order to ensure the necessary current and voltage outputs, the resistance to earth of the anodes should be carefully calculated and, where necessary, techniques should be used to lower the groundbed resistance to earth.

All factors that can affect the groundbed lifetime should be taken into account when designing a groundbed system. Interference to other structures should be prevented when selecting groundbed sites and voltage output. The presence of electrical shielding between the groundbed and the structure to be protected shall be avoided. The current distribution along the area to be protected has to be taken into account during the design phase.

A.2 Types of ground beds

A.2.1 Remote located ground beds

A cathodic protection installation equipped with a remote located groundbed provides a wide distribution of the current all over the structure to be protected.

Generally, a deep well groundbed is preferred to shallow groundbeds to provide better current distribution over the tank installation.

A.2.2 Close located groundbeds

When a close located groundbed system is used, the anodes are placed close to the tank to be protected.

Close located groundbeds are of two types:

- distributed groundbeds made of anodes that are generally placed around the tank periphery at short intervals.
- continuous groundbeds made of flexible wire anodes or anodes placed in a continuous carbonaceous backfill at adapted intervals.

With these configurations, a uniform current distribution along the structure is provided, less overall current and voltage output is needed and shielding and interference problems are generally avoided.

Shallow groundbeds, both horizontal and vertical, are generally used.

Horizontal groundbeds are installed deeper than the ring beam of the tank.

A.2.3 Anode system located under tank bottom

An anode system located directly under the bottom of tanks may be used. This method is necessary in case of the use of a plastic membrane.

An anode grid system or concentric rings made of MMO coated titanium are especially adapted to this case.

A.3 Anodes types

A.3.1 General

In this subclause the most commonly used impressed current anode materials are described.

When impressed current anodes are installed with carbonaceous backfill, a consumption rate of this backfill should be used in the design. (0,9 to 2) $\text{kg}\cdot\text{A}^{-1}\cdot\text{y}^{-1}$ for a current density of 5 $\text{A}\cdot\text{m}^{-2}$ are typical values.

A.3.2 High silicon cast iron anodes

The performance of this kind of anodes depends on the formation of a thin layer of silicon dioxide on the surface of the anode. This film is partially protective and its formation is not fully developed if the alloy contains less than 14,2 % of silicon.

Depending on the environment, the consumption rate and the maximum current density respectively vary from (0,1 to 0,5) $\text{kg}\cdot\text{A}^{-1}\cdot\text{y}^{-1}$ and from (10 to 50) A/m^2 .

If the environment close to the anodes contains a significant halide concentration, an addition of chromium (3,2 % to 5 %) can be used to maintain the consumption rate at an acceptable level.

The use of high-silicon chromium cast iron anodes can be subjected to national limitations due to possible impact on environment.

The most common anode shapes are cylindrical rods and tubes. These anodes are available both bare and pre-packaged with carbonaceous backfill inside steel canisters.

Underground applications include deep vertical, shallow vertical, or horizontal bed with or without backfill.

A.3.3 Titanium Mixed-Metal Oxide anodes

Titanium Mixed-Metal oxide (MMO) anodes consist of electro-catalytic active coatings on a high-purity titanium substrate.

The coatings usually consist of a mixture of highly conductive oxides. The titanium serves as a support for the oxides which constitute the anode material.

The following anode shapes are mostly used: tubular (both bare and pre-packaged in steel canisters filled with carbonaceous backfill), wires and rods (usually in steel canisters with carbonaceous backfill), mesh, strips, ribbon.

Based on a 20 years design life, the maximum design current density ranges from 3 A/m^2 in fine sand without chlorides, (35 to 50) A/m^2 in soil and metallurgical coke backfill, 100 A/m^2 in calcined petroleum coke backfill and fresh water (deep wells), and 500 A/m^2 for salt water (deep wells).

Titanium MMO anodes:

— are easier to handle and install;

- do not require carbonaceous backfill, saving costs and time during installation;
- provide a better uniform cathodic protection current distribution to the tank bottom.

NOTE Platinised anodes with titanium, niobium or tantalum substrates are not adapted to contact with soils due to their low chloride content.

Bibliography

- [1] API Recommended Practice 651, Second Edition, Nov. 1997, *Cathodic protection of Aboveground Petroleum Storage Tanks*
- [2] API Recommended Practice 651, Third Edition, Jan. 2007, *Cathodic protection of Aboveground Petroleum Storage Tanks*
- [3] API Standard 653, Fourth Edition, April 2009, *Tank inspection, Repair, Alteration, and Reconstruction*
- [4] NACE International Standard Recommended Practice RP0193-2001, *External Corrosion protection of On-Grade Carbon Steel Storage Tank Bottoms*
- [5] Polák J., *Some specifics of Cathodic Protection of the Bottoms of Above-ground Storage Tanks — Part 1*, Plyn (GAS), No. 9/2008, pg. 192-195
- [6] Lazarri L., Pedferri P., *Cathodic protection*, Polipress, Milan, Jan. 2006
- [7] Sommer B., Baeckmann W., *Stahlrohr Handbuch, 12th Edition, 1995, Vulkan-Verlag Essen* (ISBN 3-8027-2693-6)
- [8] EN 12499, *Internal cathodic protection of metallic structures*
- [9] EN 12501-1, *Protection of metallic materials against corrosion — Corrosion likelihood in soil — Part 1: General*
- [10] EN 12501-2:2003, *Protection of metallic materials against corrosion — Corrosion likelihood in soil — Part 2: Low alloyed and non alloyed ferrous materials*
- [11] EN 13636, *Cathodic protection of buried metallic tanks and related piping*
- [12] EN 15257, *Cathodic protection — Competence levels and certification of cathodic protection personnel*
- [13] EN 61140, *Protection against electric shock — Common aspects for installation and equipment (IEC 61140)*
- [14] EN ISO 12696, *Cathodic protection of steel in concrete (ISO 12696)*

British Standards Institution (BSI)

BSI is the independent national body responsible for preparing British Standards and other standards-related publications, information and services. It presents the UK view on standards in Europe and at the international level.

BSI is incorporated by Royal Charter. British Standards and other standardisation products are published by BSI Standards Limited.

Revisions

British Standards and PASs are periodically updated by amendment or revision. Users of British Standards and PASs should make sure that they possess the latest amendments or editions.

It is the constant aim of BSI to improve the quality of our products and services. We would be grateful if anyone finding an inaccuracy or ambiguity while using British Standards would inform the Secretary of the technical committee responsible, the identity of which can be found on the inside front cover. Similar for PASs, please notify BSI Customer Services.

Tel: +44 (0)20 8996 9001 Fax: +44 (0)20 8996 7001

BSI offers BSI Subscribing Members an individual updating service called PLUS which ensures that subscribers automatically receive the latest editions of British Standards and PASs.

Tel: +44 (0)20 8996 7669 Fax: +44 (0)20 8996 7001

Email: plus@bsigroup.com

Buying standards

You may buy PDF and hard copy versions of standards directly using a credit card from the BSI Shop on the website www.bsigroup.com/shop. In addition all orders for BSI, international and foreign standards publications can be addressed to BSI Customer Services.

Tel: +44 (0)20 8996 9001 Fax: +44 (0)20 8996 7001

Email: orders@bsigroup.com

In response to orders for international standards, BSI will supply the British Standard implementation of the relevant international standard, unless otherwise requested.

Information on standards

BSI provides a wide range of information on national, European and international standards through its Knowledge Centre.

Tel: +44 (0)20 8996 7004 Fax: +44 (0)20 8996 7005

Email: knowledgecentre@bsigroup.com

BSI Subscribing Members are kept up to date with standards developments and receive substantial discounts on the purchase price of standards. For details of these and other benefits contact Membership Administration.

Tel: +44 (0)20 8996 7002 Fax: +44 (0)20 8996 7001

Email: membership@bsigroup.com

Information regarding online access to British Standards and PASs via British Standards Online can be found at www.bsigroup.com/BSOL

Further information about British Standards is available on the BSI website at www.bsi-group.com/standards

Copyright

All the data, software and documentation set out in all British Standards and other BSI publications are the property of and copyrighted by BSI, or some person or entity that own copyright in the information used (such as the international standardisation bodies) has formally licensed such information to BSI for commercial publication and use. Except as permitted under the Copyright, Designs and Patents Act 1988 no extract may be reproduced, stored in a retrieval system or transmitted in any form or by any means – electronic, photocopying, recording or otherwise – without prior written permission from BSI. This does not preclude the free use, in the course of implementing the standard, of necessary details such as symbols, and size, type or grade designations. If these details are to be used for any other purpose than implementation then the prior written permission of BSI must be obtained. Details and advice can be obtained from the Copyright & Licensing Department.

Tel: +44 (0)20 8996 7070

Email: copyright@bsigroup.com

BSI

389 Chiswick High Road London W4 4AL UK

Tel +44 (0)20 8996 9001

Fax +44 (0)20 8996 7001

www.bsigroup.com/standards