



Standard Practice for Conducting Wire-on-Bolt Test for Atmospheric Galvanic Corrosion¹

This standard is issued under the fixed designation G 116; the number immediately following the designation indicates the year of original adoption or, in the case of revision, the year of last revision. A number in parentheses indicates the year of last reapproval. A superscript epsilon (ε) indicates an editorial change since the last revision or reapproval.

1. Scope

1.1 This practice covers the evaluation of atmospheric galvanic corrosion of any anodic material that can be made into a wire when in contact with a cathodic material that can be made into a threaded rod.

1.2 When certain materials are used for the anode and cathode, this practice has been used to rate the corrosivity of atmospheres.

1.3 The wire-on-bolt test was first described in 1955 (1),² and has since been used extensively with standard materials to determine corrosivity of atmospheres under the names CLIMAT Test (CLassify Industrial and MArine ATmospheres) (2-5) and ATCORR (ATmospheric CORROsivity) (6-9).

1.4 *This standard does not purport to address all of the safety concerns, if any, associated with its use. It is the responsibility of the user of this standard to establish appropriate safety and health practices and determine the applicability of regulatory limitations prior to use.*

2. Referenced Documents

2.1 ASTM Standards:³

- G 1 Practice for Preparing, Cleaning, and Evaluating Corrosion Test Specimens
- G 3 Practice for Conventions Applicable to Electrochemical Measurements in Corrosion Testing
- G 15 Terminology Relating to Corrosion and Corrosion Testing
- G 16 Guide for Applying Statistics to Analysis of Corrosion Data
- G 50 Practice for Conducting Atmospheric Corrosion Tests on Metals

¹ This practice is under the jurisdiction of ASTM Committee G01 on Corrosion of Metals and is the direct responsibility of Subcommittee G01.04 on Atmospheric Corrosion.

Current edition approved Nov 1, 2004. Published November 2004. Originally approved in 1993. Last previous edition approved in 1999 as G 116 – 99.

² The boldface numbers in parentheses refer to the list of references at the end of this standard.

³ For referenced ASTM standards, visit the ASTM website, www.astm.org, or contact ASTM Customer Service at service@astm.org. For *Annual Book of ASTM Standards* volume information, refer to the standard's Document Summary page on the ASTM website.

G 82 Guide for Development and Use of a Galvanic Series for Predicting Galvanic Corrosion Performance

G 84 Practice for Measurement of Time-of-Wetness on Surfaces Exposed to Wetting Conditions as in Atmospheric Corrosion Testing

G 91 Practice for Monitoring Atmospheric SO₂ Using the Sulfation Plate Technique

G 92 Practice for Characterization of Atmospheric Test Sites

G 104 Test Method for Assessing Galvanic Corrosion Caused by the Atmosphere⁴

3. Terminology

3.1 For definitions of terms used in this practice, refer to Terminology G 15. For conventions related to this method, refer to Practice G 3.

4. Summary of Practice

4.1 The practice consists of wrapping a wire of the anode material around the threads of a bolt or threaded rod of the cathode material, exposing the assembly to atmosphere, and determining mass loss of the anode wire after exposure. Reference specimens of the anode wire on a threaded, non-conductive, non-porous rod⁵ are used to separate general and crevice corrosion effects from galvanic corrosion effects.

5. Significance and Use

5.1 The small size of the wire compared to the short galvanic interaction distance in atmospheric exposures gives a large cathode-to-anode area ratio which accelerates the galvanic attack. The area between the wire and the threads creates a long, tight crevice, also accelerating the corrosion. For these reasons, this practice, with a typical exposure period of 90 days, is the most rapid atmospheric galvanic corrosion test, particularly compared to Test Method G 104. The short duration of this test means that seasonal atmospheric variability can be evaluated. (If average performance over a 1-year period is desired, several staggered exposures are required with this

⁴ Withdrawn.

⁵ Nylon 66 has been found suitable for this purpose.

technique.) Reproducibility of this practice is somewhat better than other atmospheric galvanic corrosion tests.

5.2 The major disadvantage of this test is that the anode material must be available in wire form and the cathodic material must be available in the form of a threaded rod. This should be compared to Test Method G 104 where plate or sheet material is used exclusively.

5.3 An additional limitation is that the more anodic material of the pair must be known beforehand (from information such as in Guide G 82) or assemblies must be made with the material combinations reversed.

5.4 The morphology of the corrosion attack or its effect on mechanical properties of the base materials cannot be assessed by this practice. Test Method G 104 is preferable for this purpose.

5.5 This test has been used under the names CLIMAT and ATCORR to determine atmospheric corrosivity by exposing identical specimens made from 1100 aluminum (UNS A91100) wire wrapped around threaded rods of nylon, 1010 mild steel (UNS G10100 or G10080), and CA110 copper (UNS C11000). Atmospheric corrosivity is a function of the material that is corroding, however. The relative corrosivity of atmospheres could be quite different if a different combination of materials is chosen.

6. Interferences

6.1 The manufacturing process used to make the wire and rod may affect their corrosion potentials and polarization behavior. Material in these forms may not behave galvanically the same as material in the form of interest, such as fasteners in sheet roofing for example. Although unlikely, this may even lead to a situation where reversing the materials may also reverse their anode-cathode relationship, resulting in attack during service of a material which was resistant during testing as a wire.

7. Procedure

7.1 Components:

7.1.1 The components used to construct the specimen assemblies for this test are shown in Fig. 1.

7.1.2 Prepare a 1-m length of 0.875 + 0.002-mm diameter wire of the anode material for each assembly. Other diameters may be used, however, the diameter of the wire may affect the test results, so that tests may only be compared if they use wire of similar diameters. In selecting material for the wire, consider the cold work and heat treatment of a wire may be significantly different than for the component that the exposure is modeling.

7.1.3 Make the cathode material into M12 × 1.75 (1/2 -13 -UNC) threaded rods or bolts, 100-mm long. Either metric or English threads may be used, but results may only be compared between assemblies with similar thread types.⁵

7.2 Making the Assemblies:

7.2.1 Thoroughly clean and degrease all parts before assembly in accordance with Practice G 1.

7.2.2 Determine the mass of the wire to the nearest 0.0001 g.

7.2.3 Secure one end of the wire to a threaded rod using small screws and nuts of the rod material, if possible, or of nylon, stainless steel insulated with nylon, acetal resin, or

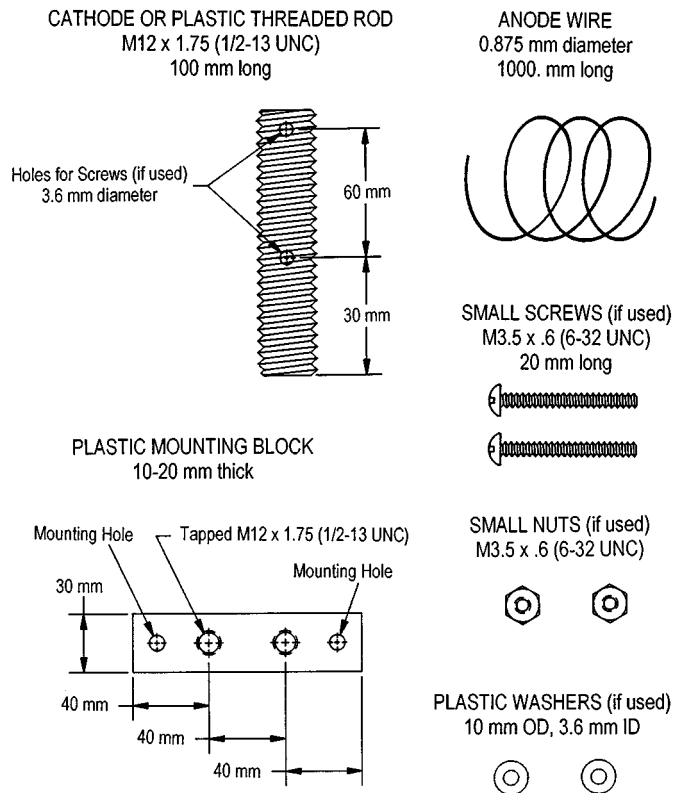

FIG. 1 Components for Making Wire-on-Bolt Exposure Assemblies

TFE-fluorocarbon. Plastic washers are usually used under the heads of the screws. The wire may instead be secured to the rod by means of a tight O-ring wrapped around the threaded rod and the wire together.

7.2.4 Wrap the wire tightly around the rod so that it lies inside the threads using a jig such as that shown in Fig. 2. This jig is used to keep constant tension on the wire while it is being wound. While using this jig, wear clean cotton gloves to prevent contamination of the surfaces of the wire or rod. If it is

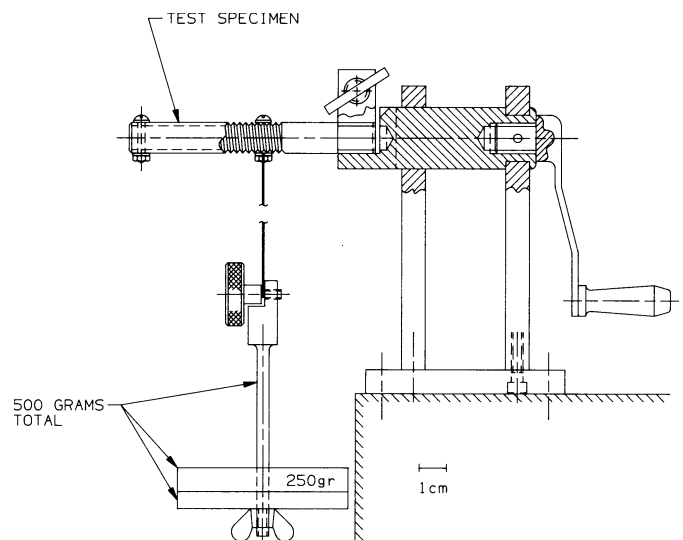

FIG. 2 Constant Tension Coil Winder for Wrapping Wire or Threaded Rods

felt that the wire tension is not critical for the particular application being tested, replace the use of the jig with hand-winding.

7.2.5 Wind the wire until it is in contact with roughly an axial distance of 50 mm of threaded rod.

7.2.6 Secure the free wire end to the rod by means of small screws and nuts made of the rod material, if possible, or nylon, stainless steel insulated with nylon, acetal resin, or TFE-fluorocarbon. Plastic washers are usually used under the heads of screws. The wire may instead be secured to the rod by means of a tight O-ring wrapped around the threaded rod and the wire together.

7.2.7 Clip off the excess wire, if any, and determine the mass of the removed piece.

7.2.8 Prepare a minimum of 3 test assemblies using rods of the cathode material and 3 reference assemblies using a nonconductive (nylon) rod for each material combination to be studied.

7.3 Mounting and Exposure:

7.3.1 Hold the assemblies vertically by screwing the rod ends furthest from the wire into plastic plates. Fig. 3 shows a schematic of a completed assembly, and Fig. 4 is a photograph of an actual completed assembly just before exposure.

7.3.2 Mount the plates horizontally on racks such as described in Practice G 50.

7.3.3 Expose the assemblies for roughly 90 days in the atmospheric site of interest.

8. Measurements

8.1 It is desirable to characterize or monitor the atmospheric site during test by using one or more of the following Practices G 84, G 91, or G 92.

8.2 After exposure visually inspect the specimens and note the condition of the wires. If any sections of wire are sufficiently corroded to have dropped out of the assembly, then the test is invalid and a shorter duration of exposure should be chosen for a retest.

8.3 Remove and clean the specimens according to the procedures specified in Practice G 1 for the material involved.

8.4 Determine the final mass of the wires.

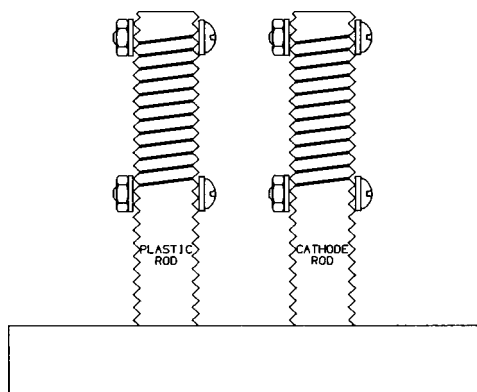

FIG. 3 Schematic Completed Wire-on-Bolt Assemblies Mounted for Exposure

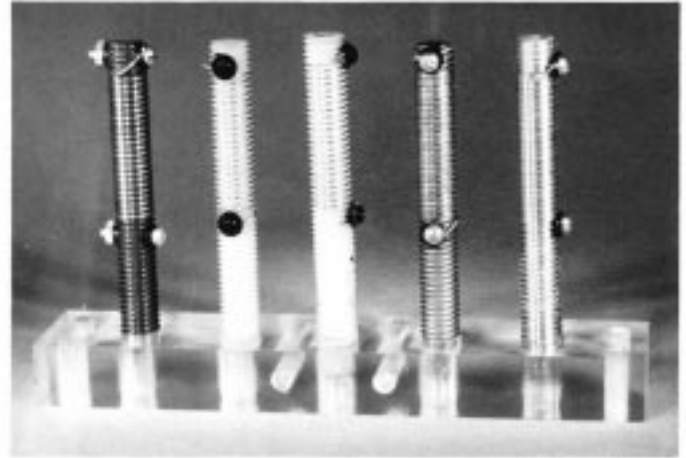

FIG. 4 Completed Wire-on-Bolt Assemblies Ready for Exposure

9. Calculation and Interpretation of Results

9.1 The wires exposed on the nonconductive rods are used for reference since they will have experienced no galvanic effects, while the test wires on the cathode rods will have experienced additional galvanic action. It is the difference between the mass loss of the wires on the cathode rods and those on the plastic rods which is an indication of galvanic corrosion.

9.2 Since the length of wire actually exposed will be slightly different for each assembly, the length differences must be corrected for. The mass loss of the wire is corrected to that for a standard 1-m length by using the mass of the wire removed as in 9.3.

9.3 Calculate the mass loss per unit length of wire for each test and reference assembly as follows:

$$\begin{aligned} \text{initial mass} &= \text{original wire mass} - \text{excess wire mass removed} \\ \text{mass loss} &= \text{initial mass} - \text{final mass (after exposure)} \\ \text{mass loss/m} &= \text{mass loss} \times \text{original wire mass/initial mass} \end{aligned}$$

This mass loss should be normalized to a 90-day period by dividing by the actual number of days of exposure and multiplying by 90.

9.4 Galvanic effects are calculated as the percent differences in the mass loss per metre between wires in the test and reference assemblies as follows:

$$\begin{aligned} \text{galvanic effect (\%)} &= \frac{\text{test mass loss/m} - \text{reference mass loss/m}}{\text{reference mass loss/m}} \times 100 \end{aligned}$$

9.5 The average and standard deviation should be calculated for mass loss per unit length of test specimens and reference specimens. The Student's *t* test should be done to determine if these mass losses are significant at the 95 % confidence level. If the difference is not significant, the galvanic effect should be reported as zero. Statistical analyses of the results should be done in accordance with Guide G 16.

9.6 If it is found after exposure that the wire on the cathode rod lost significantly less mass than the reference (negative galvanic effect) as determined by the *t* test, then it is likely that the wrong material was assumed to be the anode at the outset,

and another exposure with the roles of the two materials reversed must be conducted. If the relationship between the two materials is in doubt and time is limited, dual exposures should be conducted.

9.7 Depending on the material combinations selected and corrosivity of the atmosphere, longer or shorter exposure durations may be needed to get measurable mass loss or to prevent loss of the wire during exposure.

10. Report

10.1 Report the following information:

- 10.1.1 anode material and form, including wire diameter,
- 10.1.2 cathode material and form, including thread type used,
- 10.1.3 all wire masses,
- 10.1.4 exposure site location,
- 10.1.5 any atmospheric conditions monitored,
- 10.1.6 exposure duration,
- 10.1.7 results and calculations,
- 10.1.8 any unusual occurrences during the test,
- 10.1.9 any unusual post exposure appearance, and
- 10.1.10 statistical analyses of results if performed.

11. Precision and Bias

11.1 *Intralaboratory Variability (Repeatability)*—Standard deviation of the % mass loss of 6 specimens of magnesium wire on each of 14 different bolt materials ranged from 0.26 to 1.81 in a 100-day exposure in a New York industrial atmosphere (1). For these same samples, the coefficient of variation ranged from 0.059 to 0.266 %. Typical variability between triplicate specimens made from the CLIMAT materials is being developed in an ongoing round-robin within ASTM Committee G01 on Corrosion of Metals, Subcommittees G1.04 on Atmospheric Corrosion.

11.2 *Interlaboratory Variability (Reproducibility)*—Typical variability between results of identical specimens prepared by different laboratories and exposed at the same location is being developed in an ongoing round-robin within ASTM Committee G01 on Corrosion of Metals, Subcommittees G1.04 on Atmospheric Corrosion.

12. Keywords

12.1 aluminum; architectural materials; ATCORR test; atmospheric corrosion; atmospheric corrosivity; bolts; CLIMAT test; copper; corrosion; corrosion test; corrosivity; galvanic corrosion; rod; wire; wire-on-bolt test

REFERENCES

- (1) Compton, K. G., and Mendizza, A., “Galvanic Couple Corrosion Studies by Means of the Threaded Bolt and Wire Test,” *Symposium on Atmospheric Corrosion of Non-Ferrous Metals, STP 175*, ASTM, pp. 116–125, 1955.
- (2) Compton, K. G., Mendizza, A., and Bradley, W. W., “Atmospheric Galvanic Couple Corrosion,” *Corrosion*, Vol 11, p. 383t, 1955.
- (3) Doyle, D. P., and Godard, H. G., “A Rapid Method for Determining the Corrosivity of the Atmosphere at Any Location,” *Nature*, Vol 200, No. 4912, December 1963, pp. 1167–1168.
- (4) Doyle, D. P., and Godard, H. G., “Rapid Determination of Corrosivity of an Atmosphere to Aluminum,” *Proceedings of the Third International Congress on Metallic Corrosion*, Vol 4, pp. 429–437, MIR Publishers, Moscow, USSR, 1969.
- (5) Doyle, D. P., and Wright, T. E., “A Rapid Method for Predicting Adequate Service Lives for Overhead Conductors in Marine Atmospheres,” Paper No. 71 CP 172-PWR, presented at the IEEE Winter Power Meeting, NY, Jan–Feb 1971.
- (6) King, G. A., and Gibbs, P., “Corrosivity Mapping Around a Point Source of Pollution,” *Corrosion Australasia*, Vol. 11, No. 6, December 1986, pp. 5–9.
- (7) King, G. A., “Assessment of the Corrosivity of the Atmosphere in an Intensive Piggery using ‘CLIMAT’ Testers,” *Corrosion Australasia*, Vol. 12, No. 5, October 1987, pp. 14–15.
- (8) King, G. A., Dougherty, G. J., Dalzell, K. W., and Dawson, P. A., “Assessing Atmospheric Corrosivity in Antarctica” *Corrosion Australasia*, Vol. 13, No. 5, October 1988, pp. 13–15.
- (9) King, G. A., and Gibbs, P., “A Corrosivity Survey on a Grid of Sites Ranging from Rural to Moderately Severe Marine, Part 2 - ATCORR Indices,” *Corrosion Australasia*, Vol. 15, No. 1, February 1990, pp. 5–8.

ASTM International takes no position respecting the validity of any patent rights asserted in connection with any item mentioned in this standard. Users of this standard are expressly advised that determination of the validity of any such patent rights, and the risk of infringement of such rights, are entirely their own responsibility.

This standard is subject to revision at any time by the responsible technical committee and must be reviewed every five years and if not revised, either reapproved or withdrawn. Your comments are invited either for revision of this standard or for additional standards and should be addressed to ASTM International Headquarters. Your comments will receive careful consideration at a meeting of the responsible technical committee, which you may attend. If you feel that your comments have not received a fair hearing you should make your views known to the ASTM Committee on Standards, at the address shown below.

This standard is copyrighted by ASTM International, 100 Barr Harbor Drive, PO Box C700, West Conshohocken, PA 19428-2959, United States. Individual reprints (single or multiple copies) of this standard may be obtained by contacting ASTM at the above address or at 610-832-9585 (phone), 610-832-9555 (fax), or service@astm.org (e-mail); or through the ASTM website (www.astm.org).