

BRITISH STANDARD

**BS EN
12068:1999**

**Cathodic protection —
External organic coatings for
the corrosion protection of
buried or immersed steel
pipelines used in conjunction
with cathodic protection —
Tapes and shrinkable materials**

The European Standard EN 12068:1998 has the status of a
British Standard

ICS 23.040.99; 25.220.60; 77.060

NO COPYING WITHOUT BSI PERMISSION EXCEPT AS PERMITTED BY COPYRIGHT LAW

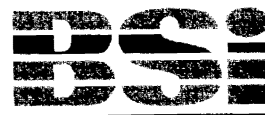

BS EN 12068:1999

National foreword

This British Standard is the English language version of EN 12068:1998.

The UK participation in its preparation was entrusted to Technical Committee ISE/16, Protective coatings and linings of metal pipes and fittings, which has the responsibility to:

- aid enquirers to understand the text;
- present to the responsible European committee any enquiries on the interpretation, or proposals for change, and keep the UK interests informed;
- monitor related international and European developments and promulgate them in the UK.

A list of organizations represented on this committee can be obtained on request to its secretary.

Cross-references

The British Standards which implement international or European publications referred to in this document may be found in the BSI Standards Catalogue under the section entitled "International Standards Correspondence Index", or by using the "Find" facility of the BSI Standards Electronic Catalogue.

A British Standard does not purport to include all the necessary provisions of a contract. Users of British Standards are responsible for their correct application.

Compliance with a British Standard does not of itself confer immunity from legal obligations.

Summary of pages

This document comprises a front cover, an inside front cover, the EN title page, pages 2 to 28, an inside back cover and a back cover.

This British Standard, having been prepared under the direction of the Engineering Sector Committee, was published under the authority of the Standards Committee and comes into effect on 15 May 1999

© BSI 05-1999

ISBN 0 580 30229 6

Amendments issued since publication

Amd. No.	Date	Text affected

EUROPEAN STANDARD
NORME EUROPÉENNE
EUROPÄISCHE NORM

EN 12068

August 1998

ICS 23.040.99; 25.220.60

Descriptors: metal protection, corrosion prevention, electrochemical corrosion, organic coatings, adhesive tapes, cathodic protection, buried pipes, submerged construction, steel tubes, specifications, operating requirements, quality, conformity tests, tests

English version

Cathodic protection — External organic coatings for the corrosion protection of buried or immersed steel pipelines used in conjunction with cathodic protection — Tapes and shrinkable materials

Protection cathodique — Revêtements organiques extérieurs pour la protection contre la corrosion de tubes en acier enterrés ou immergés en conjonction avec la protection cathodique — Bandes et matériaux rétractables

Kathodischer Korrosionsschutz — Organische Umhüllungen für den Korrosionsschutz von in Böden und Wässern verlegten Stahlrohrleitungen im Zusammenwirken mit kathodischem Korrosionsschutz – Bänder und schrumpfende Materialien

This European Standard was approved by CEN on 18 July 1998.

CEN members are bound to comply with the CEN/CENELEC Internal Regulations which stipulate the conditions for giving this European Standard the status of a national standard without any alteration. Up-to-date lists and bibliographical references concerning such national standards may be obtained on application to the Central Secretariat or to any CEN member.

This European Standard exists in three official versions (English, French, German). A version in any other language made by translation under the responsibility of a CEN member into its own language and notified to the Central Secretariat has the same status as the official versions.

CEN members are the national standards bodies of Austria, Belgium, Czech Republic, Denmark, Finland, France, Germany, Greece, Iceland, Ireland, Italy, Luxembourg, Netherlands, Norway, Portugal, Spain, Sweden, Switzerland and United Kingdom.

CEN

European Committee for Standardization
Comité Européen de Normalisation
Europäisches Komitee für Normung

Central Secretariat: rue de Stassart 36, B-1050 Brussels

© 1998 CEN All rights of exploitation in any form and by any means reserved worldwide for CEN national Members.

Ref. No. EN 12068:1998 E

Page 2
EN 12068:1998

Foreword

This European Standard has been prepared by Technical Committee CEN/TC 219, Cathodic protection, the Secretariat of which is held by BSI.

This European Standard shall be given the status of a national standard, either by publication of an identical text or by endorsement, at the latest by February 1999, and conflicting national standards shall be withdrawn at the latest by February 1999.

According to the CEN/CENELEC Internal Regulations, the national standards organizations of the following countries are bound to implement this European Standard: Austria, Belgium, Czech Republic, Denmark, Finland, France, Germany, Greece, Iceland, Ireland, Italy, Luxembourg, Netherlands, Norway, Portugal, Spain, Sweden, Switzerland and the United Kingdom.

Contents

	Page
Foreword	2
Introduction	3
1 Scope	3
2 Normative references	3
3 Definitions	4
4 Classification and designation	5
5 Requirements	6
6 Quality	9
Annex A (normative) Tape strength, elongation at break, modulus at 10 % elongation, bursting strength	11
Annex B (normative) Peel strength layer to layer	12
Annex C (normative) Peel strength to pipe surface and factory coating	13
Annex D (normative) Lap shear strength	13
Annex E (normative) Thermal ageing resistance	14
Annex F (normative) Ultraviolet irradiation resistance	16
Annex G (normative) Indentation resistance	17
Annex H (normative) Impact resistance	18
Annex J (normative) Specific electrical insulation resistance	19
Annex K (normative) Cathodic disbondment resistance	20
Annex L (informative) Saponification value	21
Annex M (normative) Microbiological resistance	22
Annex N (normative) Low temperature flexibility	23
Annex P (normative) Low temperature unrolling test	28
Annex Q (normative) Drip resistance of petrolatum tapes	28

Introduction

This European Standard gives requirements for organic coatings based on tapes or shrinkable materials for corrosion protection of buried or immersed pipelines, used in conjunction with cathodic protection.

This European Standard has been taken over from WG 6 of CEN/TC 262/SC 2, Cathodic protection, the Secretariat of which is held by DIN. There is a liaison between CEN/TC 262/SC 2/WG 6 and ECISS/TC 29/SC 4, to harmonize the standards prepared in both committees.

This is primarily a functional standard giving the requirements for the material properties necessary to ensure the function of the coating.

To ensure compatibility of the organic coatings with cathodically protected pipelines, tests of cathodic disbonding resistance at continuous operating temperature are specified. Test requirements are given for 23 °C but due to limited data available to WG 6 it is intended that values for higher temperatures will be established after five years.

Attention is drawn to the fact that degradation of the properties of a coating may occur following attack from microbiological matter. Work is to be undertaken in Europe to produce a suitable test method but this may take several years. It is considered that a burial in soil is the only satisfactory test method. The described test method is proposed for the interim period of five years.

1 Scope

This standard specifies the functional requirements and test methods for external organic coatings based on tapes or shrinkable materials to be used for corrosion protection of buried and immersed steel pipelines in conjunction with cathodic protection.

It classifies coatings by increasing mechanical resistance and operating temperatures. Coatings for special installation conditions are also considered. A comprehensive classification of coatings in relation to functional requirements is defined. Tapes and shrinkable materials which meet the requirements of these classes can belong to various types defined in this standard.

This European Standard is not applicable to special applications in off-shore and stress loads caused by frequent temperature changes.

Specifications of fillers are outside the scope of this European Standard.

2 Normative references

This European Standard incorporates by dated or undated reference, provisions from other publications. These normative references are cited at the appropriate places in the text and the publications are listed hereafter. For dated references, subsequent amendments to or revisions of any of these publications apply to this European Standard only when incorporated in it by amendment or revision. For undated references the latest edition of the publication referred to applies.

prEN 1427, *Petroleum products — Bitumen and bituminous binders — Determination of the softening point — Ring and ball method.*

EN ISO 527-3:1995, *Plastics — Determination of tensile properties — Part 3: Test conditions for films and sheets.*

(ISO/DIS 527-3:1995)

EN ISO 8503-2, *Preparation of steel substrates before application of paints and related products — Surface roughness characteristics of blast-cleaned steel substrates — Part 2: Method for the grading of surface profile of abrasive blast-cleaned steel — Comparator procedure.*

(ISO 8503-2:1988)

EN ISO 9000-1, *Quality management and quality assurance standards — Guidelines for selection and use.*

EN ISO 9000-2, *Quality management and quality assurance standards — Generic guidelines for the application of ISO 9001, ISO 9002 and ISO 9003.*

EN ISO 9001, *Quality systems — Model for quality assurance in design/development, production, installation and servicing.*

EN ISO 9002, *Quality systems — Model for quality assurance in production, installation and servicing.*

EN ISO 9003, *Quality systems — Model for quality assurance in final inspection and test.*

ISO/DIS 188, *Rubber, vulcanized — Accelerated ageing and heat resistance tests.*

ISO 1523, *Paints, varnishes, petroleum and related products — Determination of flashpoint — Closed cup equilibrium method.*

ISO 2808, *Paints and varnishes — Determination of film thickness.*

ISO 2811, *Paints and varnishes — Determination of density.*

ISO 3251, *Paints and varnishes — Determination of non-volatile matter of paints, varnishes and binders for paints and varnishes.*

ISO 3303:1990, *Rubber- or plastics-coated fabrics — Determination of bursting strength.*

ISO 3801, *Textiles — Woven fabrics — Determination of mass per unit length and mass per unit area.*

ISO 4591, *Plastics — Film and sheeting — Determination of average thickness of a sample, and average thickness and yield of a roll, by gravimetric techniques (gravimetric thickness).*

ISO 4593, *Plastics — Film and sheeting — Determination of thickness by mechanical scanning.*

Page 4
EN 12068:1998

ISO 4626, *Volatile organic liquids — Determination of boiling range.*

ISO 4892-1, *Plastics — Methods of exposure to laboratory light sources — Part 1: General guidance.*

ISO 4892-2, *Plastics — Methods of exposure to laboratory light sources — Part 2: Xenon-arc sources.*

ISO 5893, *Rubber and plastics test equipment — Tensile, flexural and compression types (constant rate of traverse) — Description.*

ISO 7254, *Paints and varnishes — Assessment of natural spreading rate — Brush application.*

ISO 8501-1, *Preparation of steel substrates before application of paints and related products — Visual assessment of surface cleanliness — Part 1: Rust grades and preparation grades of uncoated steel substrates and of steel substrates after overall removal of previous coatings.*

3 Definitions

For the purposes of this standard, the following definitions apply.

3.1 external organic coatings

3.1.1

coating

one or several layers of materials applied to the pipe in the form of tapes (spiral or "cigarette" wrapping), shrinkable materials (as delivered or constituted just prior to application) or repair materials

Coatings can consist of one or more basic types of coating materials as described in 3.2.

Primer(s) and/or filler(s) can be used in conjunction with these coating materials to improve adherence or facilitate application.

3.1.2

inner layer

coating primarily constituted to protect the pipe surface from corrosion damage

3.1.3

outer layer

coating primarily constituted to protect the inner layer from mechanical stresses

3.2 basic types of coating materials

3.2.1

petrolatum tape (cold applied)

corrosion protection tape consisting of a synthetic reinforcement coated on both sides with a semi-solid petrolatum compound mouldable at ambient temperature; it may contain an additional backing film

3.2.2

bituminous tape (hot applied)

corrosion protection tape consisting of glass or synthetic reinforcement coated on both sides with a bituminous compound.

3.2.3

polymeric tape (cold or hot applied)

corrosion protection tape consisting of a compound highly adhesive to steel and generally bonded to a flexible polymer film and may contain a synthetic reinforcement, these tapes can be subdivided into the following types:

3.2.3.1

laminate polymeric tape

corrosion protection tape consisting of a flexible polymer film, coated on one or both sides with an adhesive compound; the adhesive compound may be reinforced with synthetic fibres

3.2.3.2

reinforced polymeric tape

corrosion protection tape consisting of a synthetic reinforcement, coated on both sides with an adhesive compound and containing an additional polymer film

3.2.3.3

low strength polymeric tape

corrosion protection tape consisting only of an adhesive compound; it may contain a flexible polymer film (thickness $\leq 0,15$ mm) to avoid overstretching during application

3.2.4

shrinkable material

corrosion protection product consisting of a polymer backing capable of controlled shrinking, generally precoated on one side with an adhesive, the polymer backing can be reinforced.

Shrinkable materials are available as:

- tubular sleeves;
- wraparound sleeves with either separate or attached closure;
- tapes;
- pre-shaped materials.

3.3 complementary materials

3.3.1

primer

material applied (generally in a liquid form) as a thin film over a prepared metal surface and the adjacent pipe coating in order to ensure maximum adherence of the subsequent coating material

3.3.2

filler

mouldable material for smoothing out uneven surfaces or cavities (e.g. complicated shapes) to allow for the void-free application of tapes or shrinkable materials

NOTE Fillers will be selected by mutual agreement between manufacturer and user.

3.3.3

additional mechanical protection materials

various materials to enhance impact and indentation resistance and/or isolate movements between coated pipelines and surrounding soil

Any additional mechanical protection not completely bonded to the coating below is either perforated or electrical conductive under operating conditions to avoid screening of cathodic protection.

3.4

repair material

material used to reconstitute the coating at places where mechanical damage has occurred. It may be hot or cold applicable material; primer(s) and/or filler(s) can be applied prior to repair material if necessary

3.5 other definitions

3.5.1

maximum continuous operating temperature T_{\max}

maximum continuous temperature of the medium transported through the buried or immersed coated pipeline

3.5.2

factory coating (mill coating)

coating applied to pipe length in a factory or yard before delivery

4 Classification and designation

4.1 Classification

4.1.1 General

Coatings are classified according to resistance to mechanical damage, operating temperature or special installation conditions.

4.1.2 Mechanical resistance classes

4.1.2.1 General

Coatings are classified according to their mechanical characteristics measured by the following tests (where applicable):

- impact resistance;
- indentation resistance;
- specific electrical insulation resistance;
- cathodic disbondment resistance;
- peel strength layer to layer;
- peel strength to pipe surface and factory coating.

Coatings shall meet requirements for the following classes as specified in Table 1.

4.1.2.2 Class A

Coating which has a low mechanical resistance.

4.1.2.3 Class B

Coating which has a medium mechanical resistance.

4.1.2.4 Class C

Coating which has a high mechanical resistance.

Three alternative combinations of requirements are specified for cathodic disbondment resistance, peel strength layer to layer and peel strength to pipe surface and factory coating.

4.1.3 Maximum continuous operating temperature classes

4.1.3.1 General

Coatings are classified according to their maximum continuous operating temperature specified by the following tests (where applicable):

- indentation resistance;
- cathodic disbondment resistance;
- peel strength layer to layer;
- peel strength to pipe surface and factory coating;
- lap shear strength;
- thermal ageing resistance.

Coatings shall meet the requirements for the maximum continuous operating temperature classes as specified in Tables 1 and 2.

4.1.3.2 Class 30

In the absence of any specific indication, coatings shall be considered suitable for use at maximum continuous operating temperature T_{\max} up to 30 °C.

4.1.3.3 Class 50

Coatings in this class shall be suitable for use at maximum continuous operating temperature $T_{\max} = 50$ °C.

4.1.3.4 Class HT

Coatings in this class shall be suitable for use at maximum continuous operating temperature $T_{\max} > 50$ °C in increments of 10 °C. This temperature shall be stated in brackets.

4.1.4 Classes for special application conditions

4.1.4.1 Class L/Class VL

4.1.4.1.1 General

For these classes of coatings it shall be possible to handle products and the coated pipe at temperatures below -5 °C. They shall meet the requirements specified in Table 2.

4.1.4.1.2 Class L

For low temperatures between -20 °C and -5 °C.

4.1.4.1.3 Class VL

For very low temperatures lower than -20 °C.

In this case, the minimum handling and laying temperature shall be agreed between user and manufacturer. This temperature shall be stated in brackets.

4.1.4.2 Class UV

Coatings in this class shall be suitable for storage for prolonged periods while exposed to sunlight and shall comply with the resistance to ultraviolet irradiation required in Table 2.

Page 6
EN 12068:1998

4.2 Designation

Coatings shall be designated as follows:

EN 12068 — Mechanical resistance class — Maximum continuous operating temperature class — Class for special application conditions (if applicable).

EXAMPLE 1

Designation of a coating of medium mechanical resistance (class B) for temperatures up to 30 °C (class 30):

coating EN 12068-B 30.

EXAMPLE 2

Designation of a coating of high mechanical resistance (class C) which is suitable for use up to 50 °C (class 50) and for handling and laying at low temperatures between -20 °C and -5 °C (class L):

coating EN 12068-C 50 L.

EXAMPLE 3

Designation of a coating of high mechanical resistance (class C) which is suitable for use up to 60 °C (class HT) with proven ultraviolet irradiation resistance (class UV):

coating EN 12068-C HT 60 UV.

5 Requirements

5.1 Requirements for coatings

Coatings shall meet the requirements for the particular class as specified in Tables 1 and 2.

Table 1 — Requirements for coatings

No.	Property	Operating temperature class	Unit	Mechanical resistance classes					Test method
				A	B	C ¹⁾			
1	Impact resistance at 23 °C	30/50/HT	J	≥ 4	≥ 8	≥ 15	≥ 15	≥ 15	Annex H
2	Indentation resistance pressure (test condition) at 23 °C	30/-/-	N/mm ²	0,1	1,0	10,0	10,0	10,0	Annex G
	at T _{max}	-/50/HT	N/mm ²	0,1	1,0	10,0	10,0	10,0	
	Holiday detection or or residual thickness	— mm	pass ≥ 0,6	pass ≥ 0,6	pass ≥ 0,6	pass ≥ 0,6	pass ≥ 0,6	pass ≥ 0,6	
3	Specific electrical insulation resistance R _{s100}	30/50/HT	Ω·m ²	≥ 10 ⁶	≥ 10 ⁸	≥ 10 ⁸	≥ 10 ⁸	≥ 10 ⁸	Annex J
	R _{s100} /R _{s70} ²⁾		—	≥ 0,8	≥ 0,8	≥ 0,8	≥ 0,8	≥ 0,8	
4	Cathodic disbondment resistance at 23 °C	30/50/HT	mm	≤ 20	≤ 20	≤ 10	≤ 15	≤ 20	Annex K
	at T _{max}	-/50/HT	mm			3)			
5	Peel strength ^{4) 5)} layer to layer		N/mm						Annex B
	— inner to inner + outer to inner at 23 °C	30/50/HT		≥ 0,8	≥ 0,8	≥ 1,0	≥ 1,5	≥ 1,5	
	at T _{max}	-/50/HT		≥ 0,2	≥ 0,2	≥ 0,2	≥ 0,2	≥ 0,2	
	— outer to outer at 23 °C	30/50/HT		≥ 0,2	≥ 0,2	≥ 0,2	≥ 0,2	≥ 0,2	
6	Peel strength ^{6) 7)} to pipe surface at 23 °C	30/50/HTE	N/mm	≥ 0,4	≥ 0,4	≥ 0,5	≥ 0,75	≥ 1,0	Annex C
	at T _{max}	-/50/HTE		≥ 0,04	≥ 0,04	≥ 0,05	≥ 0,075	≥ 0,1	
	to factory coating at 23 °C	30/50/HTE		≥ 0,2	≥ 0,2	≥ 0,4	≥ 0,4	≥ 0,4	
	at T _{max}	-/50/HTE		≥ 0,02	≥ 0,02	≥ 0,04	≥ 0,04	≥ 0,04	
7	Lap shear strength ⁴⁾ at 23 °C	30/-/-	N/mm ²	≥ 0,05	≥ 0,05	≥ 0,05	≥ 0,05	≥ 0,05	Annex D
	at T _{max}	-/50/HTE		≥ 0,05	≥ 0,05	≥ 0,05	≥ 0,05	≥ 0,05	

1) See 4.1.2.4: coatings shall meet all requirements in one column.

2) If the specific electrical insulation resistance after 70 days is less than a factor 10 greater than the specified value for 100 days.

3) By agreement between manufacturer and user.

4) No requirement for petrolatum tapes in class A.

5) No requirement for bituminous tapes in class A and class B.

6) If the result for bituminous tapes or reinforced polymeric tapes is less than 0.4 N/mm, residual thickness of bituminous compound or of adhesive compound on the pipe surface or factory coating shall be E 0,25 mm.

7) Petrolatum tapes shall be capable of adhering and remain attached to all clean metal surfaces and shall leave a film of compound on the metal when peeled off at an angle of 180°, 30 min after application.

Table 2 — Requirements for coatings

No.	Property	Classes	Requirements	Test method
1	Microbiological resistance	all classes	by convention ¹⁾	Annex M
2	Thermal ageing resistance ^{2) 3)} Ratio of — tape strength or — bursting strength — elongation at break — peel strength layer to layer — peel strength to pipe surface	all classes ^{2) 3)}	$1,25 \geq S_{100}/S_0 \geq 0,75$ $S_{100}/S_{70} \geq 0,8$ $1,25 \geq B_{100}/B_0 \geq 0,75$ $B_{100}/B_{70} \geq 0,8$ $1,25 \geq E_{100}/E_{70} \geq 0,75$ $E_{100}/E_{70} \geq 0,8$ $P_{100}/P_T \geq 0,75$ $P_{100}/P_{70} \geq 0,8$ $A_{100}/A_T \geq 0,75$ $A_{100}/A_{70} \geq 0,8$	Annex E
3	Ultraviolet irradiation resistance Ratio of — elongation break — tape strength or — bursting strength	class UV only	$1,25 \geq E_X/E_0 \geq 0,75$ $1,25 \geq S_X/S_0 \geq 0,75$ $1,25 \geq B_X/B_0 \geq 0,75$	Annex F
4	Low temperature flexibility at -20°C at lower than -20°C (agreed temperature)	class L class VL	no separation, tears or cracks	Annex N
5	Low temperature unrolling test at -5°C /ambient temperature ⁴⁾ at -20°C at lower than -20°C (agreed temperature)	all classes ⁴⁾ class L class VL	no separation, tears or cracks	Annex P
6	Drip resistance of petrolatum tapes	all classes	no dripping of components	Annex Q
¹⁾ By convention between manufacturer and user. ²⁾ No requirement for petrolatum tapes in class A. ³⁾ No requirement for bituminous tapes in class A and class B. ⁴⁾ -5°C or minimum ambient temperature, as given by the manufacturer, during product handling and laying of the pipeline. No requirement for hot applied materials described in 3.2.2, 3.2.3 and 3.2.4.				

5.2 Manufacturer's information

The manufacturer shall give sufficient information to identify the coating and shall supply as a minimum the technical information of the coating components as listed in Tables 3 to 7.

The values to be given are typical values obtained by testing by the manufacturer for information for the user.

6 Quality

6.1 Conformity evaluation

Conformity with this standard shall be demonstrated by initial testing (type testing) to the requirements for the particular class as set out in Tables 1 and 2.

Type testing shall be repeated within five years and whenever a change is made, which may influence the specified properties.

6.2 Quality assurance

Manufacturer shall operate an effective, documented quality system, e.g. a quality system based on the relevant part of the EN ISO 9000 to EN ISO 9003 and maintain records identifying the product, dates of manufacturing and/or batch numbers and all results of inspection and testing.

Table 3 — Coating identification

No.	Property	Reference
1	Coating trade name	—
2	Basic type of coating material	see 3.2
3	Primer trade name	—
4	Structure of the coating	see 3.2
4.1	Number of layers ¹⁾	—
4.2	First layer trade name	—
4.3	Second layer trade name	—
4.4	Subsequent layer trade name	—
5	European Standard designation	see 4.2
6	Nominal thickness of the coating	—
7	Compatible factory coatings ²⁾	—

¹⁾ Excluding primer.
²⁾ State all types of factory coating that have been tested successfully with the coating.

Table 4 — Coating properties
(refer to Table 1 and Table 2: Requirements for coatings)

No.	Property	Table	Unit	Test method
1	Impact resistance	1	J	Annex H
2	Indentation resistance: residual thickness	1	mm	Annex G
3	Specific electrical insulation resistance	1	$\Omega \cdot m^2$	Annex J
4	Cathodic disbondment resistance ¹⁾	1	mm	Annex K
5	Peel strength layer to layer ^{1) 2)}	1	N/mm	Annex B
6.1	Peel strength to pipe surface ¹⁾	1	N/mm	Annex C
6.2	Peel strength to factory coating ^{1) 3)}	1	N/mm	Annex C
7	Lap shear strength ¹⁾	1	N/mm ²	Annex D
8	Ultraviolet irradiation resistance (outer layer)	2	—	Annex F

¹⁾ Values to be given for 23 °C and maximum continuous operating temperature T_{max} , if applicable.
²⁾ To be given for combinations of layers in Table 1.
³⁾ To be given for each compatible factory coating in Table 3, item 7.

Table 5 — Primer

No.	Property	Unit	Test method
1	Primer trade name	—	—
2	Generic type of primer	—	—
3	Solid content	% mass	ISO 3251
4	Saponification value (solids)	mg/g	Annex L
5	Type of solvent	—	ISO 4626
6	Flash point	°C	ISO 1523
7	Density	g/cm ³	ISO 2811
8a	Spreading rate (coverage) or	m ² /l	ISO 7254
8b	Dry film thickness	μm	ISO 2808
9	Storage conditions	—	—
9.1	Storage temperature		
	minimum	°C	—
	maximum	°C	—
9.2	Shelf life at storage temperature	month	—

Page 10
EN 12068:1998

Table 6 — Tape, shrinkable material, repair material¹⁾

No.	Property	Unit	Test method
1	Trade name	—	—
2	Description of coating material	—	—
3	Colour	—	—
4a	Minimum total thickness or	mm	ISO 4591/ ISO 4593
4b	Mass per unit area	g/m ²	ISO 3801
5	Polymeric film/reinforcement	—	—
5.1	Generic type of polymeric film	—	—
5.2	Generic type of reinforcement material	—	—
5.3a	Nominal thickness or	mm	ISO 4591/ ISO 4593
5.3b	Mass per unit area	g/m ²	ISO 3801
6	Adhesive	—	—
6.1	Generic type of adhesive	—	—
6.2a	Nominal thickness or	mm	ISO 4591/ ISO 4593
6.2b	Mass per unit area	g/m ²	ISO 3801
6.3	Saponification value	mg/g	Annex L
6.4	Softening point ring and ball ²⁾	°C	prEN 1427
7	Mechanical properties of component	—	—
7.1a	Tape strength or	N/mm	Annex A
7.1b	Bursting strength	N	Annex A
7.2	Modulus at 10 % elongation ²⁾	N/mm	Annex A
7.3	Elongation at break ²⁾	%	Annex A
7.4	Low temperature flexibility ²⁾ (class L and VL only)	°C	Annex N
7.5	Shrinkage (shrinkable material only) ³⁾	%	³⁾
8	Storage conditions	—	—
8.1	Storage temperature	—	—
	minimum	°C	—
	maximum	°C	—
8.2	Shelf life at storage temperature	month	—

¹⁾ Data to be supplied for each coating component.
²⁾ If applicable.
³⁾ In accordance with manufacturer's test method.

Table 7 — Application instructions

No.	Property	Unit
1	Ambient conditions	
1.1	Minimum temperature	°C
1.2	Maximum temperature	°C
1.3	Relative humidity	%
2	Surface preparation	
2.1	Metal surface	—
2.1.1	Cleanliness (in accordance with ISO 8501-1)	—
2.1.2	Profile (in accordance with ISO 8503-2)	—
2.2	Factory coating	—
3	Application of primer	
3.1	Method of application	—
3.2	Surface temperature	minimum °C maximum °C
3.3	Potlife	h
3.4	Overcoating time	minimum h or min maximum d or h
3.5	Curing temperature	°C
4	Application of tape	
4.1	Method of application	—
4.2	Minimum product temperature (in accordance with annex P)	°C
4.3	Minimum overlap of tape	%
5	Application of shrinkable material	
5.1	Surface temperature	°C
5.2	Method of preheat	—
5.3	Shrink temperature	°C
6	General	
6.1	Minimum overlap on factory coating ¹⁾	mm
6.2	Specific application instructions	—
6.3	Holiday detection voltage	kV
6.4	Repair procedures	—

¹⁾ To be given for each compatible factory coating in Table 3, item 7.

Annex A (normative)**Tape strength, elongation at break, modulus at 10 % elongation, bursting strength****A.1 General**

The test method consists of measuring the value of tape strength (maximum force per unit width), elongation at break and modulus (tensile force per unit width) at 10 % elongation of tapes with and without reinforcement and shrinkable materials without reinforcement in accordance with EN ISO 527-3. Shrinkable materials with reinforcement shall be measured for bursting strength in accordance with method A of ISO 3303:1990.

A.2 Apparatus

Tensile testing machine, in accordance with ISO 5893 allowing the stress-strain curve to be recorded and capable of operating at a constant rate of separation or compression of the clamps of 100 mm/min.

A.3 Preparation of the test specimens**A.3.1 Tapes with or without reinforcement and shrinkable materials without reinforcement****A.3.1.1 Tapes with or without reinforcement**

Sample tapes as delivered after conditioning for 24 h at $(23 \pm 2)^\circ\text{C}$. Discard the three outer turns from the roll. Unwind sufficient tape to cut five specimens in the longitudinal direction. Condition this length of tape for a minimum of 1 h at $(23 \pm 2)^\circ\text{C}$ on a flat surface.

- a) Tapes without reinforcement: prepare five test specimens type 5 in accordance with Figure 2 of EN ISO 527-3:1995.
- b) Tapes with reinforcement: prepare five rectangular test specimens, 200 mm long and 50 mm wide or the tape width if narrower.

A.3.1.2 Shrinkable material without reinforcement

Sample shrinkable material by free shrinking in accordance with the manufacturer's instruction. Take specimens circumferentially and condition for a minimum of 1 h at $(23 \pm 2)^\circ\text{C}$.

Prepare five test specimens of type 5 in accordance with Figure 2 of EN ISO 527-3:1995.

A.3.2 Shrinkable material with reinforcement

Prepare five circular test specimens with a diameter of 100 mm, punched out of three different units.

A.4 Procedure**A.4.1 Tape strength, elongation at break, modulus at 10 % elongation of tapes with or without reinforcement and shrinkable materials without reinforcement**

The test is carried out at $(23 \pm 2)^\circ\text{C}$.

Mark suitable reference points on each test specimen and clamp the ends into the grips of the tensile machine:

- a) (80 ± 5) mm apart for specimens without reinforcement;
- b) (100 ± 1) mm apart for specimens with reinforcement.

Set the tensile testing machine in operation at a constant separation rate of 100 mm/min and continuously record the force and elongation.

Repeat for all five specimens. Reject all specimens that break within 15 mm of the clamps and carry out further tests to obtain five satisfactory readings.

A.4.2 Bursting strength of shrinkable materials with reinforcement

The test specimens are held by a clamping device in accordance with Figure 1 of method A of ISO 3303:1990. The clamping device and the ball are pressed against each other with a constant rate of compression of 100 mm/min until the specimen fails due to the pressure exerted by the ball.

A.5 Expression of results

For tapes and shrinkable materials without reinforcement calculate the elongation at break E using the equation (A.1):

$$E = (L_1 - L_0) \times 100/L_0 \quad (\text{A.1})$$

For tapes with or without reinforcement and for shrinkable material without reinforcement calculate the tape strength S using the equation (A.2):

$$S = F_B/b \quad (\text{A.2})$$

In the case of shrinkable materials with reinforcement calculate the bursting strength B in newtons.

Calculate the modulus at 10 % elongation M_{10} using the equation (A.3):

$$M_{10} = F_{10}/b \quad (\text{A.3})$$

where

- E is the elongation at break, as a percentage;
- L_0 is the initial gauge length of the specimen, in millimetres;
- L_1 is the gauge length, in millimetres;
- S is the tape strength, in newton per millimetre width;
- F_B is the maximum force, in newton;
- b is the width of specimen, in millimetres;
- B is the bursting strength, in newton;
- M_{10} is the modulus at 10 % elongation, in newton per millimetre width;
- F_{10} is the force to give 10 % elongation, in newton.

Take the arithmetic mean of five results.

Annex B (normative)

Peel strength layer to layer

B.1 General

The test method consists of measuring the peel strength (peeling force per unit width) between two layers of tapes or shrinkable materials.

Peel strength is determined for:

- inner layer to inner layer;
- outer layer to inner layer;
- outer layer to outer layer.

B.2 Apparatus

- Tensile testing machine*, in accordance with ISO 5893 allowing the peeling force to be recorded and capable of operating at a constant rate of separation of 100 mm/min.
- Equipment for the tensile testing machine*, allowing the specimen to be maintained at the test temperature.
- Lower rigid support plate* (e.g. glass plate) about 50 mm × 300 mm × 5 mm.
- Rigid upper plate* (e.g. steel plate about 50 mm × 200 mm × 5 mm) with a smooth cellular rubber on its lower side (thickness of the rubber 1 mm to 3 mm).
- A *load* which produces a combined pressure of 0,01 N/mm² together with the upper plate.
- Pipe sections* DN 100, 100 mm long for shrinkable material only.
- Release paper*.

B.3 Preparation of the test specimen

Condition the samples for a minimum of 24 h at $(23 \pm 2)^\circ\text{C}$.

B.3.1 Tapes

Discard the three outer turns from the roll.

Cut strips 250 mm to 280 mm in length, 50 mm wide or of tape width in the case of narrower tapes. Locate one strip of the first tape (6), adhesive side down on release paper (3) on the lower plate (4). Apply the second tape strip (5) with the same dimensions exactly over the first. At one end insert a piece of release paper between the two tape strips for 50 mm to 80 mm. Place release paper (3), the rubber coating (2) and the upper plate with the load onto the specimen (pressure 0,01 N/mm²) (1) and store for seven days at $(23 \pm 2)^\circ\text{C}$ (see Figure B.1).

It is permissible to apply additional supporting films to the outer surfaces of the specimens to prevent excessive elongation during the test.

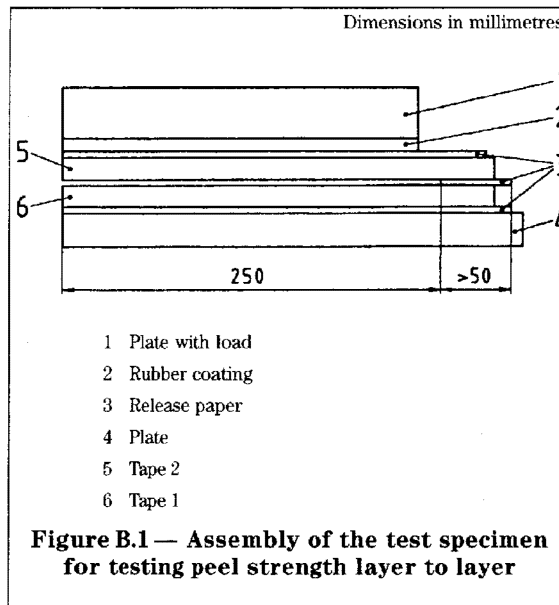

B.3.2 Shrinkable materials

Wrap the pipe section DN 100, 100 mm long circumferentially with two layers of the shrinkable material one after another in accordance with the manufacturer's instruction. Store for a minimum of 24 h at $(23 \pm 2)^\circ\text{C}$.

B.4 Procedure The peel strength test is carried out on:

- three of each specimen layer to layer at $(23 \pm 2)^\circ\text{C}$;
- three of each specimen layer to layer at the maximum operating temperature ($T_{\text{max}} \pm 2)^\circ\text{C}$ if this is higher than 30°C .

B.4.1 Tapes

Clamp the end of the two tapes into the grips of the tensile testing machine. Precondition the test specimen at the specified test temperature for at least 0,5 h. Maintain the specimen at the specified test temperature throughout the test. Set the tensile testing machine in operation at a constant rate of separation of 100 mm/min. Record the peeling force continuously.

B.4.2 Shrinkable materials

Cut the coating with a double saw or knife around the circumference down to the pipe wall to an inside width of 50 mm. Cut the resulting outer strip with a knife perpendicular to the circumference of the pipe and lift the end of the outer strip over a length of about 20 mm from the inner strip.

Clamp the test specimen into the grips of the tensile testing machine.

Precondition the specimen at the specified test temperature for at least 1 h.

Maintain the specimen at the specified test temperature throughout the test. Set the tensile testing machine in operation at a constant rate of separation of 100 mm/min. Record the peeling force continuously.

B.5 Expression of result

Calculate the mean value of the peel strength in newtons per millimetre width using at least 20 points at regular intervals. Disregard the first and last 50 mm of the peeling length. If any values are less than 75 % of the specified peel strength given in Table 1, test a further three specimens. No further failure is allowed.

Take the arithmetic mean value of the result of the three test specimens.

Annex C (normative)**Peel strength to pipe surface and factory coating****C.1 General**

The test method consists of measuring the peel strength (peeling force per unit width) between the coating made from tapes or shrinkable materials and the pipe with a metallic surface or all of the factory coatings recommended by the manufacturer.

C.2 Apparatus

- a) *Tensile testing machine*, in accordance with ISO 5893 allowing the peeling force to be recorded and capable of operating at a constant rate of separation of 10 mm/min.
- b) *Equipment to support the pipe section*, perpendicular to the direction of the peeling and to rotate freely about the axis of the pipe section.
- c) *Equipment for the tensile testing machine*, allowing the test specimen to be maintained at the test temperature.
- d) *Pipe sections* DN 100, 100 mm long with a metal surface.
- e) *Pipe sections* DN 100, 100 mm long with the specified factory coating.

C.3 Preparation of the test specimens

The metal surface of the pipe section shall be blast cleaned in accordance with ISO 8501-1 grade Sa 2½ to give a medium profile in accordance with EN ISO 8503-2. Pipe sections shall be kept clean and dry and primer and/or coating shall be applied within 8 h.

The factory coating shall be cleaned in accordance with instructions of the manufacturer of the tape or shrinkable material. The cleaning procedure shall be agreed upon with the manufacturer of the factory coating.

Apply the tape system or the shrinkable material to the pipe in accordance with the manufacturer's instructions. Wrap the tapes circumferentially and not spirally.

Store the prepared test specimen for a minimum of 7 days at $(23 \pm 2) ^\circ\text{C}$.

C.4 Procedure

The peel strength test shall be carried out on:

- a) three pipe sections according to C.2d) at $(23 \pm 2) ^\circ\text{C}$;
- b) three pipe sections according to C.2e) at $(23 \pm 2) ^\circ\text{C}$;
- c) three pipe sections according to C.2d) at the maximum continuous operating temperature $(T_{\text{max}} \pm 2) ^\circ\text{C}$ if this is higher than $30 ^\circ\text{C}$;
- d) three pipe sections according to C.2e) at the maximum continuous operating temperature $(T_{\text{max}} \pm 2) ^\circ\text{C}$ if this is higher than $30 ^\circ\text{C}$.

Prior to testing, cut the wrapping with a double saw or knife around the circumference down to the pipe wall to an inside width of 50 mm. Cut the resulting 50 mm strip with a knife, perpendicular to the circumference of the pipe, and lift one end from the pipe over a length of about 20 mm. Precondition the test specimen at the specified test temperature for at least one hour. Peel off the strip in the peeling device with a tensile testing machine perpendicular to the axis of the pipe at a constant rate of separation of 10 mm/min.

Maintain the test specimen at the specified test temperature throughout the test.

Record the peeling force continuously.

C.5 Expression of result

Calculate the mean value of the peel strength in newton per millimetre width using at least 20 points at regular intervals. Disregard the first and last 50 mm of the peeling length. If any values are less than 75 % of the specified peel strength, test a further three test specimens. No further failure is allowed.

Take the arithmetic mean value of the results of the three test specimens.

Annex D (normative)**Lap shear strength****D.1 Lap shear strength of tape coatings****D.1.1 General**

The test method consists of measuring the lap shear strength (maximum force per unit area) obtained in shearing a single overlap joint between a plate with metallic surface or factory coating and the coating system by applying a tensile force which is parallel to the bond area and to the major axis of the specimen.

D.1.2 Apparatus

- a) *Tensile testing machine*, in accordance with ISO 5893 allowing the shear force to be recorded and capable of operating at a constant rate of separation of 10 mm/min.
- b) *Equipment for the tensile testing machine*, allowing the specimen to be maintained at the test temperature;
- c) *Steel plates*, (length: 100 mm, width: 50 mm or of tape width in the case of narrower tapes).

D.1.3 Preparation of the test specimens

The metal surface of the steel plate shall be blast cleaned in accordance with ISO 8501-1 grade Sa 2½, to give a medium profile in accordance with EN ISO 8503-2. The steel plates shall be kept clean and dry and primer and/or coating shall be applied within 8 h.

The factory coating shall be cleaned in accordance with instructions of the manufacturer of the tape. The cleaning procedure shall be agreed upon with the manufacturer of the factory coating.

Apply the coating systems (all layers) to one side of the plates in accordance with the manufacturer's instructions, such that the coating overhangs one end by 30 mm to 40 mm to allow clamping in the testing machine. Store the test specimens for a minimum of 7 days at $(23 \pm 2)^\circ\text{C}$ under a load of $0,01 \text{ N/mm}^2$.

Prior to testing, cut the coating transversely so that the effective shear length is 20 mm.

D.1.4 Procedure

The lap shear strength test shall be carried out on:

- five test specimens at $(23 \pm 2)^\circ\text{C}$; or
- five test specimens at the maximum continuous operating temperature $(T_{\text{max}} \pm 2)^\circ\text{C}$ if this is higher than 30°C .

Clamp the test specimen into the tensile testing machine, ensuring that the plate (metal surface) and the coating system are in the same plane.

For the test temperature $\geq 50^\circ\text{C}$, precondition the test specimens at the specified test temperature for at least 0,5 h.

Maintain the test specimen at the specified test temperature throughout the test.

Set the tensile testing machine to a constant rate of separation of 10 mm/min. Record the maximum force.

If the tape breaks instead of shearing, prepare new test specimens so that the effective shear length is 10 mm. Repeat for five test specimens.

D.1.5 Expression of result

Calculate the arithmetic mean of five results of the lap shear strength, in newtons per square millimetre.

If the tape breaks, express the lap shear strength as greater than the breaking force in newtons per bonded area in square millimetres.

D.2 Lap shear strength of shrinkable material coatings

D.2.1 General

The test method consists of measuring the maximum stress obtained in shearing a single overlap joint between two plates with metallic surface or factory coating bonded with the adhesive of the shrinkable material by applying a tensile force which is parallel to the bond area and to the major axis of the test specimen.

D.2.2 Apparatus

See D.1.2.

D.2.3 Preparation of the test specimens

The metal surface of the steel plate shall be blast cleaned in accordance with ISO 8501-1 grade Sa ½ to give a medium profile in accordance with EN ISO 8503-2. The steel plates shall be kept clean and dry and primer and/or adhesive shall be applied within 8 h.

The factory coating shall be cleaned in accordance with instructions of the manufacturer of the shrinkable material. The cleaning procedure shall be agreed upon with the manufacturer of the factory coating.

Coat one side of the plates with the adhesive of the shrinkable material to a thickness of 1 mm.

Position a second plate in such a way that the overlap of the two plates is 20 mm. Treat the test specimens in accordance with the manufacturer's instructions (pressure, temperature and time). Store the test specimens for at least 24 h at $(23 \pm 2)^\circ\text{C}$.

Remove any adhesive which has exuded at the sides during preparation.

D.2.4 Procedure

See D.1.4.

D.2.5 Expression of result

See D.1.5.

Annex E (normative)

Thermal ageing resistance

E.1 Tape strength, elongation at break, bursting strength

E.1.1 General

The test method consists of measuring the effect of subjecting test specimens of tapes or shrinkable materials to dry heat in a thermostatically controlled oven.

The effect of ageing is to assess by the change in tape strength, elongation at break or bursting strength (see annex A).

E.1.2 Apparatus

A thermostatically controlled oven in accordance with ISO 188, normal oven method, capable of being set to a temperature of 50°C or $(T_{\text{max}} + 20)^\circ\text{C}$ to an accuracy of 2°C . The oven shall be of sufficient size to allow test sheets to be suspended vertically without restriction (T_{max} = maximum continuous operating temperature).

E.1.3 Preparation of the test specimens

Prepare three sheets of material (shrinkable materials after free shrinking according to the manufacturer's instructions) sufficiently large to prepare at least five test specimens from each as specified in annex A.

Identify each sheet as (a), (b) or (c).

E.1.4 Procedure

Ageing temperature: 50 °C or ($T_{max} + 20$) °C.

- a) Store sheet (a) in a dark room at room temperature for 100 days.
- b) Hang sheet (b) in an oven at the ageing temperature for 70 days, followed by 30 days at room temperature in a dark room.
- c) Hang sheet (c) in an oven at the ageing temperature for 100 days.

Precondition the unaged test specimens (a) for 1 h at the ageing temperature before testing.

After the ageing period, prepare from each sheet at least five specimens as specified in annex A and test all specimens within 8 h for elongation at break and tape strength or bursting strength under identical conditions in accordance with annex A. The test temperature is (23 ± 2) °C.

E.1.5 Expression of result

For materials with and without reinforcement calculate the ratio of the tape strength S or the ratio of the bursting strength B

$$S_{100}/S_0 \text{ or } B_{100}/B_0$$

$$S_{100}/S_{70} \text{ or } B_{100}/B_{70}$$

where

- S_0 is the tape strength without heat ageing (arithmetic mean of five results);
- S_{70} is the tape strength after heat ageing for 70 days (arithmetic mean of five results);
- S_{100} is the tape strength after heat ageing for 100 days (arithmetic mean of five results);
- B_0 is the bursting strength without ageing (arithmetic mean of five results);
- B_{70} is the bursting strength after heat ageing for 70 days (arithmetic mean of five results);
- B_{100} is the bursting strength after heat ageing for 100 days (arithmetic mean of five results).

For materials without reinforcement calculate the ratio of the elongation at break E .

$$E_{100}/E_0$$

$$E_{100}/E_{70}$$

where

- E_0 is the elongation at break without heat ageing (arithmetic mean of five results);
- E_{70} is the elongation at break after heat ageing for 70 days (arithmetic mean of five results);
- E_{100} is the elongation at break after heat ageing for 100 days (arithmetic mean of five results).

E.2 Peel strength layer to layer

E.2.1 General

The test method consists of measuring the effect of subjecting test specimens layer to layer prepared as described in annex B to dry heat in a thermostatically controlled oven.

The effect of ageing shall be assessed by the change in peel strength layer to layer in accordance with annex B.

E.2.2 Apparatus

See E.1.2.

E.2.3 Preparation of the test specimens

Prepare six test specimens for each ageing test peel strength layer to layer in accordance with annex B of the following types:

- a) inner layer to inner layer;
- b) outer layer to inner layer;
- c) outer layer to outer layer.

Identify each specimen.

E.2.4 Procedure

Ageing temperature: 50 °C or ($T_{max} + 20$) °C.

- a) Hang three specimens of each type for 70 days in an oven at the ageing temperature, followed by 30 days at room temperature in a dark room.
- b) Hang three specimens of each type for 100 days in an oven at the ageing temperature.

After the ageing period, test all specimens within eight hours for peel strength layer to layer under identical conditions in accordance with annex B at a test temperature of (23 ± 2) °C.

E.2.5 Expression of result

Calculate the arithmetic mean of the peel strength in accordance with annex B.

Calculate the ratio of the peel strength:

$$P_{100}/P_T$$

$$P_{100}/P_{70}$$

where

- P_T is the peel strength layer to layer at 23 °C as specified in Table 1;
- P_{70} is the peel strength layer to layer at 23 °C after heat ageing for 70 days (arithmetic mean of three results);
- P_{100} is the peel strength layer to layer at 23 °C after heat ageing for 100 days (arithmetic mean of three results).

Page 16
EN 12068:1998

E.3 Peel strength to pipe surface

E.3.1 General

The test method consists of measuring the effect of subjecting test pipes with metallic surface coated with tapes or shrinkable materials to dry heat in a thermostatically controlled oven.

The effect of ageing is to assess by the change in peel strength to pipe surface in accordance with annex C.

E.3.2 Apparatus

See E.1.2.

E.3.3 Preparation of the test specimens

Prepare six test specimens for testing peel strength to pipe surface in accordance with annex C for each ageing test.

Identify each specimen.

E.3.4 Procedure

Ageing temperature: 50 °C or ($T_{\max} + 20$) °C.

- a) Store three test specimens for 70 days in an oven at the ageing temperature, followed by 30 days at room temperature in a dark room;
- b) Store three test specimens for 100 days in an oven at the ageing temperature.

After the ageing period, test all test specimens within eight hours for peel strength under identical conditions in accordance with annex C at the test temperature of (23 ± 2) °C.

E.3.5 Expression of result

Calculate the arithmetic mean of the peel strength in accordance with annex C.

Calculate the ratio of the peel strength:

$$A_{100}/A_T$$

$$A_{100}/A_{70}$$

where

- A_T is the peel strength to pipe surface at 23 °C as specified in Table 1;
- A_{70} is the peel strength to pipe surface at 23 °C after heat ageing for 70 days (arithmetic mean of three results);
- A_{100} is the peel strength to pipe surface at 23 °C after heat ageing for 100 days (arithmetic mean of three results).

Annex F (normative)

Ultraviolet irradiation resistance

F.1 General

The test method consists of measuring the effect of subjecting test specimens of tapes or shrinkable materials to continuous irradiation of a xenon lamp under fixed temperature and humidity conditions (see ISO 4892-1 and ISO 4892-2).

The effect of ageing is to assess by the variation in elongation at break. In the case of tapes with reinforcement the variation in tape strength shall be used as the test criterion. In the case of shrinkable material with reinforcement the variation in bursting strength shall be used.

F.2 Apparatus

An irradiation chamber equipped with a xenon lamp (see ISO 4892-2).

F.3 Preparation of the test specimens

The test is carried out on tapes designed for outer wrapping and on shrinkable material after free shrinking in accordance with the manufacturer's instruction.

Cut two pieces of sufficient size to prepare at least five test specimens required for the test in accordance with annex A.

F.4 Procedure

Store one of the test pieces in the dark at room temperature. Expose the other test piece under the following conditions:

- a) artificial weathering (method A);
- b) black standard temperature (65 ± 3) °C;
- c) relative humidity (65 ± 5) %;
- d) spray cycle 18 min spray, 102 min dry;
- e) total radiant energy 5 GJ/m²;
- f) continuous exposure.

Test five irradiated and five non-irradiated test specimens as required in annex A (taken from test pieces) under identical conditions within 8 h.

F.5 Expression of result

- a) For samples without reinforcement

Calculate the ratio of the arithmetic mean of the elongations at break E of the irradiated and the non-irradiated test specimens:

$$E_X/E_0$$

where

- E_0 is the elongation at break without irradiation (arithmetic mean of five results);
- E_X is the elongation at break after irradiation (arithmetic mean of five results).

- b) For samples with reinforcement:

Calculate the ratio of the arithmetic mean of the tape strength S or the bursting strength B of the irradiated and the non-irradiated test specimens:

$$S_X/S_0 \quad \text{or} \quad B_X/B_0$$

where

- S_0 is the tape strength without irradiation (arithmetic mean of five results);
- S_X is the tape strength after irradiation (arithmetic mean of five results);
- B_0 is the bursting strength without irradiation (arithmetic mean of five results);
- B_X is the bursting strength after irradiation (arithmetic mean of five results).

Annex G (normative)

Indentation resistance

G.1 General

The test method consists of measuring the coating continuity by a high voltage detector and/or measuring the residual thickness of the coating after compression between a blunt rod (indenter) and a flat plate or pipe under a specific pressure.

G.2 Apparatus

- A *test unit* shall consist of a *cylindrical steel rod* that can freely move vertically without friction to bear at right angles on to a specimen. The rod shall have a *platform* to apply weights to its upper end and *indentors* of 11,3 mm, 5,65 mm or 1,8 mm diameter to its lower end (see Table G.1).
- A *dial gauge*, capable of measuring to $\leq 0,05$ mm shall be attached to measure the vertical travel of the steel rod.
- A *ground steel plate*, 8 mm thick \times 75 mm \times 75 mm for tapes or an inside supported steel pipe section DN 100, 100 mm long, minimum wall thickness of 3 mm for shrinkable materials.
- An *adjustable high voltage holiday detector* with a single probe capable of being set to a voltage of up to $(15 \pm 0,5)$ kV.

G.3 Preparation of test specimens

G.3.1 General

The test specimens shall consist of the complete coating system. Prepare three test specimens.

G.3.2 Tapes

Specimens of each layer measuring at least 50 mm \times 50 mm shall be applied to the ground steel plate.

G.3.3 Shrinkable materials

The shrinkable materials shall be applied and shrunk in accordance with the manufacturer's instruction to a length of heavy wall pipe DN 100.

G.3.4 Conditioning

The prepared specimens shall be conditioned for at least 16 h:

- at (23 ± 2) °C for coatings with a maximum continuous operating temperature of 30 °C for class 30; or
- at maximum continuous operating temperature $(T_{\max} \pm 2)$ °C for classes 50 and HT.

G.4 Procedure

Attach the indenter appropriate to the class to the steel rod. Place the indenter on an uncovered part of the ground steel plate or pipe and record the reading T_1 . Position the indenter centrally over the specimen, apply the appropriate weight to the platform of the rod to give the correct class pressure and record the time (see Table G.1).

After (72 ± 1) h at the test temperature, measure and record the final reading T_2 .

The difference between the initial reading T_1 and the final reading T_2 is the residual thickness of the coating T_3 [see equation (G.1)]:

$$T_3 = T_2 - T_1 \quad (\text{G.1})$$

Remove the weight and indenter and within 3 min test the indented area with the high voltage holiday detector at a test voltage of 5 kV/mm of original thickness of the coating with a maximum of 15 kV.

Table G.1 — Indenter diameters and pressures

Class	Pressure ($\pm 5\%$) N/mm ²	Indenter diameter mm
A	0,1	11,30 \pm 0,10
B	1,0	5,65 \pm 0,05
C	10,0	1,80 \pm 0,05

G.5 Expression of result

Report the result, pass or fail for all test temperatures and classes. Report for the manufacturer's data (see 5.2, of Table 4) the residual thickness, test temperature and class.

Annex H (normative)**Impact resistance****H.1 General**

The test method consists of measuring the resistance of the coating to impact damage by dropping a spherical impactor on to the applied coating with a determined impact energy.

Freedom from damage is assessed by testing the impact site using a high voltage holiday detector.

H.2 Apparatus

The apparatus (see Figure H.1) shall consist of a *weighted impactor* (13) with a *calibrated vertical guide* (14) aligned over a *horizontal support* (6) for the coated test specimen (5).

The $(25 \pm 0,1)$ mm diameter hemispherical hardened steel *impactor* (4) shall be fixed centrally to the lower end of a cylindrical steel *falling body* (outside diameter $(35 \pm 0,5)$ mm) (13). The impactor shall be free from damage or irregularities.

Total falling weights are given in Table H.1.

Table H.1 — Impact energy

Impact energy J	Total falling weight g	Drop height mm
4	408 ± 2	$1\ 000 \pm 5$
8	815 ± 4	$1\ 000 \pm 5$
15	$1\ 529 \pm 7$	$1\ 000 \pm 5$
30	$3\ 058 \pm 15$	$1\ 000 \pm 5$

To determine intermediate values of impact resistance the drop height may be varied using the nearest higher falling weight.

The vertical guide consists of a *vertical tube* with internal diameter $(40 \pm 0,5)$ mm (2), (15), with four 10 mm wide and 1 000 mm long slots (1), (11) [one for guide (3), (14) and three for air release (11)] or an equal device capable of guiding the fall of the weighted impactor with minimum friction on to the specimen from a predetermined height of up to 1 000 mm (impact energy see Table H.1). A *device for measuring the drop height* with an accuracy of 5 mm shall be provided.

The horizontal specimen support (6) consists of a 75 mm diameter *cylindrical steel bar* supported at each end on *steel pillars* 60 mm high (9), (10). One end of the horizontal bar shall be hinged (7) and the other shall be clamped (8) (see Figure H.1). The length of the bar (6) between the pillars shall be (400 ± 5) mm.

- a) *Length of DN 100 steel pipe*, 250 mm long and minimum wall thickness of 3 mm (5).
- b) A *high voltage holiday detector*, with a single probe capable of being set to a voltage of up to $(15 \pm 0,5)$ kV.

H.3 Preparation of test specimens

Prepare the surface of the pipe in accordance with the manufacturer's instruction.

H.3.1 Tapes

The required number of layers of each tape specified by the manufacturer shall be applied to the entire pipe length in accordance with the manufacturer's instruction except that they shall be applied spirally, edge to edge, without overlaps.

H.3.2 Shrinkable materials

Shrinkable material coatings shall be applied to the entire pipe length in accordance with the manufacturer's instruction.

H.4 Procedure

Condition the coated test specimen for at least 2 h at (23 ± 2) °C. Support the coated test specimen on the horizontal support (6) (steel bar) of the test apparatus so that the impactor (4) will fall vertically on to the crown.

Adjust the impact energy to the value specified in Table H.1 appropriate to the class of coating with an accuracy of 0,5 %.

Allow the weighted impactor (13) to fall freely on to the test specimen. Carefully raise the impactor (4) and test the impact site with the high voltage holiday detector at a test voltage of 5 kV/mm of original thickness of the coating with a maximum of 15 kV.

Carry out 10 separate impacts on sites at least 30 mm apart.

For the manufacturer's information (see 5.2, Table 4) increase the impact energy by increments of 1 J and plot the impact energy against the number of perforations to obtain the maximum impact resistance.

H.5 Expression of results

The coating shall pass the test at the specified impact energy if no holidays are recorded after 10 impacts.

The maximum impact resistance shall be taken as the impact energy at the point of inflexion on the graph where the number of perforations increases rapidly.

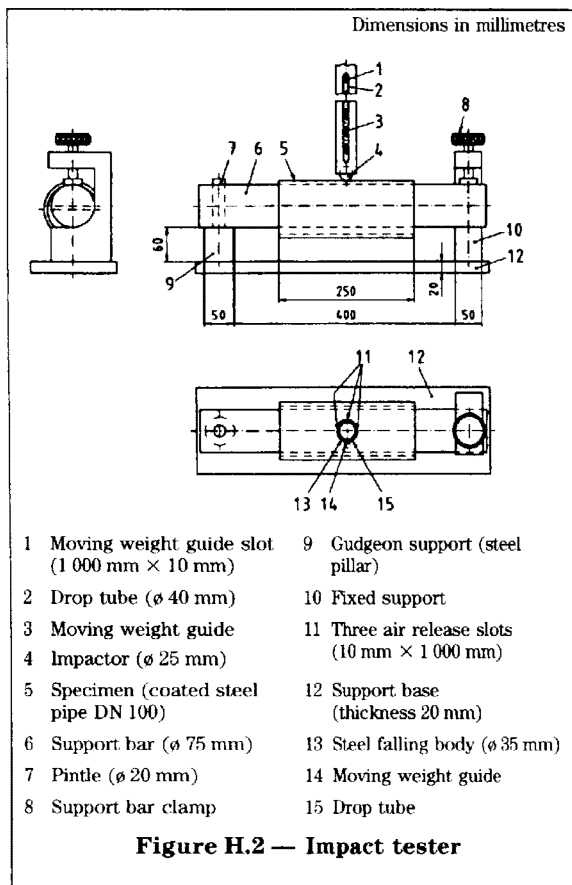

The immersion of the pipe can be undertaken in one of two ways.

- a) The prepared specimen shall be placed horizontally in a plastics container through appropriate holes in the opposite faces of the side walls. The entry of the pipe shall be sealed with a suitable non-conductive sealant.
- b) The prepared specimen shall be sealed at one end with a suitable non-conductive sealant ensuring that the metal pipe is prevented from contact with the sodium chloride (NaCl) solution. The specimen shall be supported vertically in a plastics container.

Fill the container with the sodium chloride (NaCl) solution.

J.4 Procedure

Immerse at least 10 cm² of the counter electrode into the solution.

The test shall be carried out at (23 ± 2) °C.

For each measurement, connect the positive pole of the d.c. supply to the end of the pipe that is not immersed and the negative pole to the counter electrode.

Only apply the voltage during measurements. Measure the resistance using an ohmmeter or record voltage *U* and current *I* after one minute. Continue to monitor the measurement at weekly intervals for a total of 100 days. The first measurement shall be taken after three days.

If the resistance of any one specimen falls below the specified value the test shall be re-started with three new specimens.

NOTE The measured value of resistance or current will be only that due to current passing through the submerged coating. If the requirement of Table 1 is not met check whether there is a current leakage.

J.5 Expression of results

Calculate the specific electrical resistance *R_s* using the equation (J.1):

$$R_s = \frac{US}{I} = R_1 S \tag{J.1}$$

where

- R_s* is the calculated specific electrical resistance, in ohm square metres;
- R₁* is the measured electrical resistance of the submerged specimen, in ohms;
- U* is the voltage between counter electrode and pipe, in volts;
- S* is the submerged surface area of coating, in square metres;
- I* is the measured current in amperes.

Plot a graph of specific electrical resistance against time. Between the 70th day (*R_{S70}*) and 100th day (*R_{S100}*), the linear straight regression line shall be calculated from the measured values. Using the regression line calculate the ratio of the specific electrical resistance:

$$R_{S100}/R_{S70}$$

Annex J (normative)

Specific electrical insulation resistance

J.1 General

The test method consists of measuring the specific electrical insulation resistance (electrical resistance of the coating in relation to the surface area of the coated pipe) by exposure to a sodium chloride solution over a 100 day period.

J.2 Apparatus

- a) *Direct current (d.c.) supply*, with a voltage ≥ 50 V.
- b) *Voltmeter*, with an accuracy of 0,1 V and ammeter with an accuracy of 5 % reading of the requirements in Table 1 or d.c. ohmmeter with equivalent accuracy.
- c) *Inert counter electrode* (copper) of at least 10 cm² area with conducting connectors for pipe and electrode to power supply.

J.3 Preparation of test specimen

Three 0,5 m lengths of pipe at least DN 50 prepared in accordance with ISO 8501-1 grade Sa 2½ shall be coated in accordance with the manufacturer's instruction. The coated area shall be at least 0,03 m². Prepare sufficient 0,1 mol/l sodium chloride (NaCl) solution.

Annex K (normative)**Cathodic disbondment resistance****K.1 General**

The test method consists of measuring the cathodic disbondment resistance (the comparative resistance to disbondment of the coating under negative polarization at a specified potential).

The test shall be carried out at $(23 \pm 2)^\circ\text{C}$ for classes 30/50/HT, at $(50 \pm 2)^\circ\text{C}$ for class 50 and at maximum continuous operating temperature ($T_{\text{max}} \pm 2)^\circ\text{C}$ for class HT. When the maximum continuous operating temperature exceeds 50°C the electrolyte temperature shall be controlled at $(50 \pm 5)^\circ\text{C}$.

K.2 Apparatus and materials**K.2.1 Electrical equipment**

- Stabilized d.c. power unit, having controlled voltage output between 0 V and 12 V and a current capacity sufficient to supply 20 mA to each test site. Alternatively the use of potentiostatic control is allowed.
- Adjustable voltage by *potentiometer* with an accuracy of 5 mV;
- Variable resistors, 0 k Ω to 1 k Ω \pm 10 %.

K.2.2 Heating and cooling equipment

- A *thermostatically controlled apparatus*, for heating the test specimen to the test temperature $\pm 2^\circ\text{C}$.
- A *neutral glass cooling coil* (5), to control the temperature of the electrolyte to $(50 \pm 5)^\circ\text{C}$.

K.2.3 Construction of test cell

Suitable reference electrodes are given in Table K.1.

Table K.1 — Reference electrodes

Reference electrode	Test potential at 25 °C V	Temperature coefficient mV/°C
Ag/AgCl/sat. KCl	-1,38	+1,0
Ag/AgCl/3 M KCl	-1,39	+1,0
Hg/Hg ₂ Cl ₂ /sat. KCl	-1,42	+0,65
Cu/CuSO ₄ /sat. CuSO ₄	-1,50	+0,97

- The reference electrodes shall be constructed from glass or plastics with a porous plug. The diameter of the plug shall be less than 10 mm (1).
- Anode: minimum length 75 mm of platinum wire of 0,8 mm nominal diameter or of platinized titanium strip 6 mm wide and 1,5 mm thick or of platinized titanium wire of 6 mm nominal diameter (2).
- Rigid plastics tube test cell: nominal bore 50 mm to 80 mm and length approximately 90 mm for each test site (6).
- Thermometer with an accuracy of 1 °C.
- Elastomeric adhesive material for sealing the plastics tube to the surface of the test specimens (8).

K.2.4 Electrolyte

The electrolyte shall be a 0,5 mol/l solution of sodium chloride (NaCl analytical grade) in distilled or de-ionized water (11).

K.2.5 Miscellaneous

- High voltage holiday detector*, with a single probe capable of being set to a voltage of up to $(15 \pm 0,5)$ kV.
- Twist drill*, of 6 mm diameter with cutting edges at an included angle of 160°.

K.3 Preparation of test specimens

Three test specimens shall be prepared as follows.

A length of standard steel pipe of not less than 60,3 mm diameter and 3,9 mm wall thickness (10) shall be prepared in accordance with ISO 8501-1 grade Sa 2½ to give a medium profile in accordance with EN ISO 8503-2.

Primer or tape or shrinkable materials shall be applied to the pipe within 1 h of blasting and in accordance with the instruction of the manufacturer of the coating material (9).

Samples shall be checked for pin-holes using the holiday detector set at a test voltage of 5 kV/mm of original thickness of the coating with a maximum of 15 kV.

In the centre of the sample, drill a 6 mm hole through the coating to the substrate. Ensure the depth of the holiday is minimal and that no coating is visible within the area of the holiday. Avoid excessive penetration into the steel substrate. Remove any swarf or detached coating from the specimen.

The anode (2) shall be fixed perpendicularly and at 10 mm above the holiday. The reference electrode (1) shall be located within 10 mm above the holiday and within 20 mm of the anode (see Figure K.1).

K.4 Procedure

The test cell shall be filled with the electrolyte (see K.2.4). The apparatus shall be assembled as in Figure K.1.

The temperature of the test specimens shall be maintained within $\pm 2^\circ\text{C}$ of the test temperature during the whole test period. The temperature of the electrolyte shall be controlled at $(50 \pm 5)^\circ\text{C}$ for tests carried out at a temperature exceeding 50°C .

The level of the electrolyte in the cell shall be (75 ± 5) mm.

Adjust to give a test potential according to Table K.1 between the reference electrode and the pipe with an accuracy of 10 mV. After the sample and the electrolyte have reached stable temperature the test potential shall be controlled and if necessary adjusted.

The test shall be continued for 28 days. The level of the electrolyte shall be re-adjusted with distilled or de-ionized water, if necessary.

Every 24 h the test potential shall be measured and adjusted, if necessary.

K.5 Inspection

When the test is complete, the sample shall be washed with water and dried with filter paper.

After drying, the test specimen shall be examined as follows:

Make six radial incisions using a sharp knife through the coating to the substrate, extending outwards from the holiday for at least 30 mm and at an angle of approximately 60° from each other. Insert the knife point under the sections and, using a gentle levering action, pull away slowly each section until firm adhesion is reached. Measure the length from the edge of the holiday area to the furthest extent for each segment.

Calculate the arithmetic mean of these six single values.

K.6 Expression of result

Report the cathodic disbondment in millimetres as the arithmetic mean of the results of the three specimens.

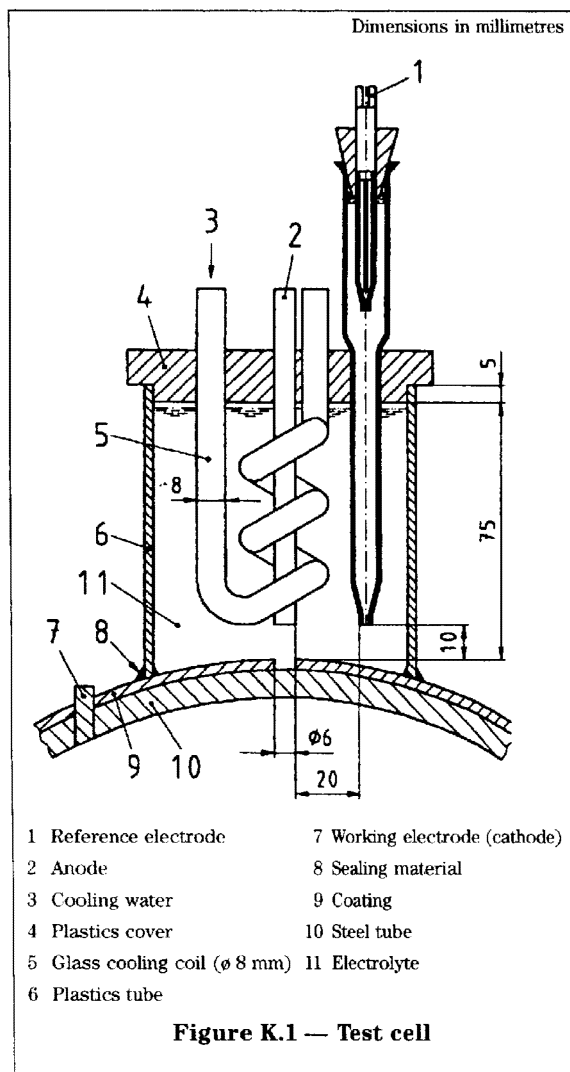

Annex L (informative)

Saponification value

L.1 General

The saponification is the formation of alkali salts from organic acids. The test method consists of measuring the amount of saponifiable material (esterified acids, free acids and acid anhydrides) in the coating material.

The saponification value is the number of milligrams of potassium hydroxide (KOH) required for the saponification of 1 g of the non-volatile matter of the coating material.

As various filling materials can give a higher saponification value and the type of fillers is unknown in most cases, fillers shall always be separated before determining the saponification value.

L.2 Preparation of the test material

Depending on the type of corrosion protection material, three methods may be used to separate the filler.

a) *Method A: hot filtration.* ($4 \pm 0,01$) g of the material shall be dissolved by heating in 100 ml of solvent suitable for all organic components, which itself is unsaponifiable. If necessary, the solution shall be filtered by means of a heatable funnel. The residue shall be washed twice with 25 ml of hot solvent.

b) *Method B: extraction.* ($4 \pm 0,01$) g of the material shall be treated in the Soxhlet apparatus. A Soxhlet extractor with an extraction volume of 70 ml and a round flask of 250 ml shall be used. 150 ml of a solvent (see method A) shall be used for extraction. Extraction shall be continued until the mass in the extraction thimble dried at 150 °C remains constant.

c) *Method C: centrifuging.* ($4 \pm 0,01$) g of the material shall be mixed with the solvent (see method A) in the centrifugal glass beaker and placed in a water or sand bath. The dissolution process can be accelerated by occasional stirring with a glass rod. After dissolution, the mixture shall be centrifuged and the clear eluant decanted. The residue shall be mixed with solvent, heated and centrifuged and decanted again. Solvent is added to the eluant collected until a quantity of 150 ml is reached.

L.3 Procedure

The filler-free solution shall be mixed with 50 ml of propanol-2 and ($25 \pm 0,03$) ml of ethanolic potassium hydroxide solution with a substance concentration $c(\text{KOH}) = 0,1 \text{ mol/l}$ and reflux heated for 30 min to boiling. Then, preferably after adding 25 ml of water, the excess of potassium hydroxide solution shall be cooled to 23 °C and titrated with ethanolic hydrochloric acid with a substance concentration $c(\text{HCl}) = 0,1 \text{ mol/l}$ using a glass electrode and a reference electrode or single-bar electrode chain. The titration end-point is reached at a pH of 10,5. For the titration the use of a motor piston burette synchronized with a recording pH measuring device is advisable. The consumption of potassium hydroxide solution by the solvents used is determined in a blank test.

L.4 Expression of result

Calculate the saponification value S by the following equation (L.1):

$$S = 56,1 \frac{(V_0 - V_1) \times c}{m} \quad (\text{L.1})$$

where

- S is the saponification value, in mg KOH/g of the specimen;
- V_0 is the volume, in millilitres, of the hydrochloric acid solution, used for the blank test;
- V_1 is the volume, in millilitres, of the hydrochloric acid solution, used for the determination;
- c is the actual concentration, of HCl in mol/l, of the hydrochloric acid solution at the time of use;
- m is the mass, in grams, of the test material.

Calculate the arithmetic mean of two determinations, and report the result to one decimal place.

Annex M (normative)**Microbiological resistance****M.1 General**

Microbiological resistance is the ability of the coating to withstand degradation by micro-organisms while buried in a specified soil under controlled temperature and humidity.

The test method consists of measuring the change in tape strength, elongation at break or bursting strength according to annex A and the change in peel strength to pipe surface according to annex C after burial.

Safety measures. Attention is drawn to the national recommendations and orders on personal safety for handling and working with micro-organisms and microbiological agencies. The general safety regulations for microbiological laboratories are to be observed.

M.2 Apparatus

- a) *Testing machines and utensils*, as described in annex A and annex C.
- b) A *dark oven*, capable of controlling at a temperature of $(30 \pm 1)^\circ\text{C}$ and at a relative humidity of $(95 \pm 5)\%$.
- c) *Receptacles*, approximately 170 mm long, 170 mm wide and 170 mm deep.
- d) *Spatula*.
- e) Usual *utensils* in microbiological laboratories.

M.3 Preparation and testing of the soil

The test soil shall consist of previously sifted compost produced by the decomposition of garden earth, leaves, herbivore manure and sand.

NOTE A sizeable stock of several cubic metres should be prepared and stored under conditions of controlled temperature and humidity.

The soil shall have the following properties:

pH	6 to 7,5;
carbon/nitrogen ratio	8 to 15;
water content	$(30 \pm 2)\%$ by mass.

The soil shall be analysed before filling receptacles. Determine the water content by drying 50 g of the test sample in an oven controlled at 100 to 105 °C until constant mass is achieved (equation M.1):

$$B = 2A \quad (\text{M.1})$$

where

- A is the quantity of water in the test sample;
- B is the percentage of the water content of the soil by mass.

Adjust the water content:

- a) If the water content is greater than 30 % by mass:
 - spread the soil thinly and allow to dry at room temperature.

Do not apply heat as this may destroy the microorganisms.

- b) If the water content is less than 30 % by mass:
 - add distilled or deionized water according to the equations (M.2) and (M.3):

$$X = \frac{30(100 - B)}{70} - B = \frac{300 - 10B}{7} \quad (\text{M.2})$$

and

$$X_1 = \frac{Xc}{100} \quad (\text{M.3})$$

where

- X is the number of millilitres of water to be added to each 100 g of soil;
- 30 is the desired water content, in %, by mass;
- B is the water content present, in % by mass;
- C is the mass, in grams, of soil used;
- X_1 is the number of millilitres of water to be added to C .

Use five test pieces (150 mm × 20 mm) of bleached linen weave cotton with a mass per area of approximately 125 g/m² and a break strength of approximately 10 N/mm. Soak them in water for 15 min, then, using the spatula, bury the test pieces vertically in one of the receptacles.

Place, together with the other receptacles intended for the burial test, in the oven for eight days.

Examine the cotton test pieces of which should then exhibit no strength. If this state has not been reached, discard all the soil in the receptacles and repeat with another soil sample.

M.4 Preparation of test specimens

The test specimens shall be prepared:

- a) as described in annex A, sufficient to measure before burial and after six months' burial;
- b) as described in annex C, C.2d), C.3 and C.4 sufficient to measure before burial and after one month's, three months' and six months' burial.

Before burial, each specimen shall be pre-cut to the steel, as specified in C.4.

M.5 Procedure

When the cotton test is successful (see M.3), measure the tape strength, elongation at break or bursting strength in accordance with annex A and the peel strength to pipe surface in accordance with annex C and bury the rest of the test specimens in the receptacles at 30 °C and 95 % humidity.

- a) After six months' burial clean the test specimens [see M.4a)], make a visual examination and measure the tape strength, elongation at break or bursting strength in accordance with annex A.
- b) After one month, three months and six months clean the test specimens [see M.4b)], make a visual examination and measure the peel strength to pipe surface in accordance with annex C.

Test temperature shall be (23 ± 2) °C.

M.6 Expression of results

Note the results of the visual examination. Calculate the arithmetic mean of the results in each case and calculate additionally:

- a) the ratio of the tape strength S_6/S_0 (tapes with or without reinforcement and shrinkable material without reinforcement),

where

S_6 is the tape strength after six months' burial;

S_0 is the tape strength before burial;

- b) the ratio of the elongation at break E_6/E_0 (tapes and shrinkable material without reinforcement),

where

E_6 is the elongation at break after six months' burial;

E_0 is the elongation at break before burial;

- c) the ratio of the bursting strength B_6/B_0 (shrinkable material with reinforcement only),

where

B_6 is the bursting strength after six months' burial;

B_0 is the bursting strength before burial;

- d) the ratio of peel strength to pipe surface A/A_0 ,

where

A is the peel strength after one month's (A_1), three months' (A_3), six months' (A_6) burial,

A_0 is the peel strength before burial.

Annex N (normative)**Low temperature flexibility****N.1 General**

The test method consists of measuring the flexibility of coating material at low temperature. Before cooling and testing the flexibility, the specimens are kept at (50 ± 2) °C for 24 h.

N.2 Apparatus

Figures N.1 to N.8 show parts of the test equipment:

rectangular aluminium vessel 222 mm × 170 mm × 70 mm (7) and with 25 mm of suitable external insulation (9);

the vessel (7) shall contain *clamps* (1), (2) and (3), a *cylindrical mandrel* of 10 mm diameter (5), a *holder* (4) and a *handle* (6).

N.3 Preparation of test specimens

The test shall be carried out on shrinkable materials and on samples of tapes as delivered. Condition and prepare the specimens as described in annex A.

Cut three specimens of each coating material to an approximate length of 130 mm and width of 10 mm.

N.4 Procedure

The specimens (maximum 15 pieces) shall be fixed between clamps (1) and (2) on one side and (2) and (3) on the other side.

In the case of polymeric tapes or shrinkable materials with one adhesive layer only the specimens shall be fixed with the adhesive layer facing down, while in the case of polymeric tapes with two adhesive layers the interleaving shall be kept on the upper face and clamped.

Place the specimens in clamps (1) and (2) and in clamps (2) and (3) with the mandrel (5) in position A (see Figure N.1 and Figure N.3). The length of the specimen between the clamps shall be 100 mm and be in light tension to avoid wrinkles or visible defects.

Place the assembly in an oven at (50 ± 2) °C for 24 h. Remove and allow to cool to ambient temperature and after 24 h fill the vessel (7) with ethanol (8) to a level of approximately 40 mm. Add solid carbon dioxide to the ethanol (8) until the test temperature T is reached.

Maintain the specimens at this temperature for 15 min and then rotate the handle (6) to position B (see Figure N.2), thus folding the specimen over the mandrel (5). Remove specimens and examine for separation, tears or cracks. All specimens shall be undamaged.

- a) Test temperature T : -20 °C for class L,
- b) Test temperature T : agreed temperature for class VL.

N.5 Expression of results

Report pass or fail.

Equipment for testing low temperature flexibility

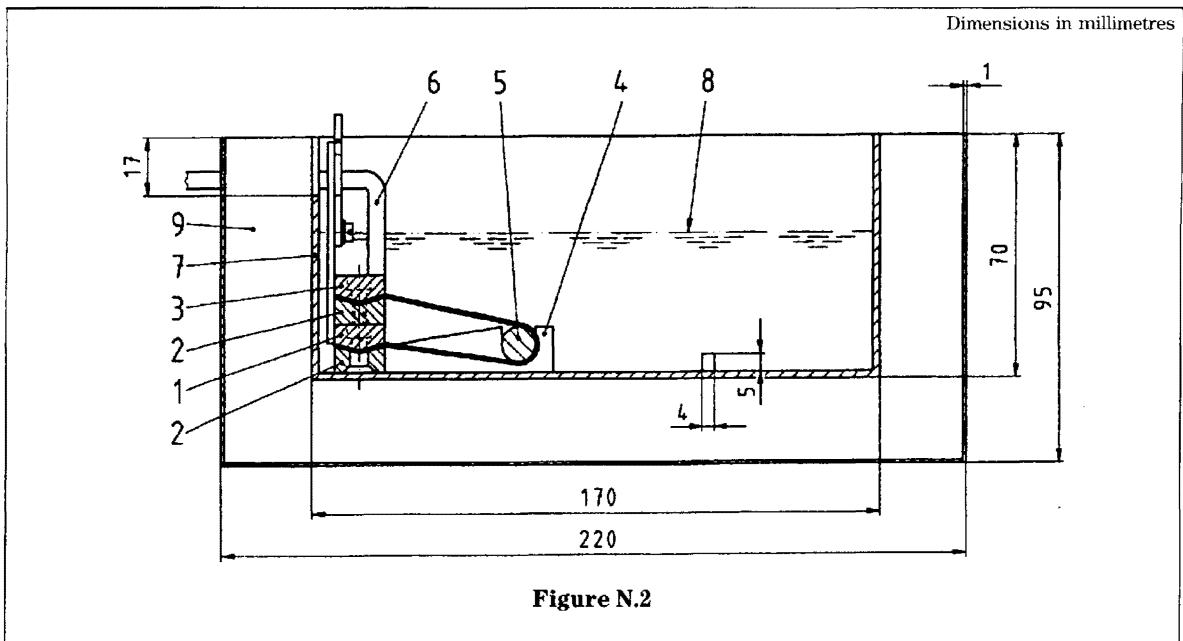
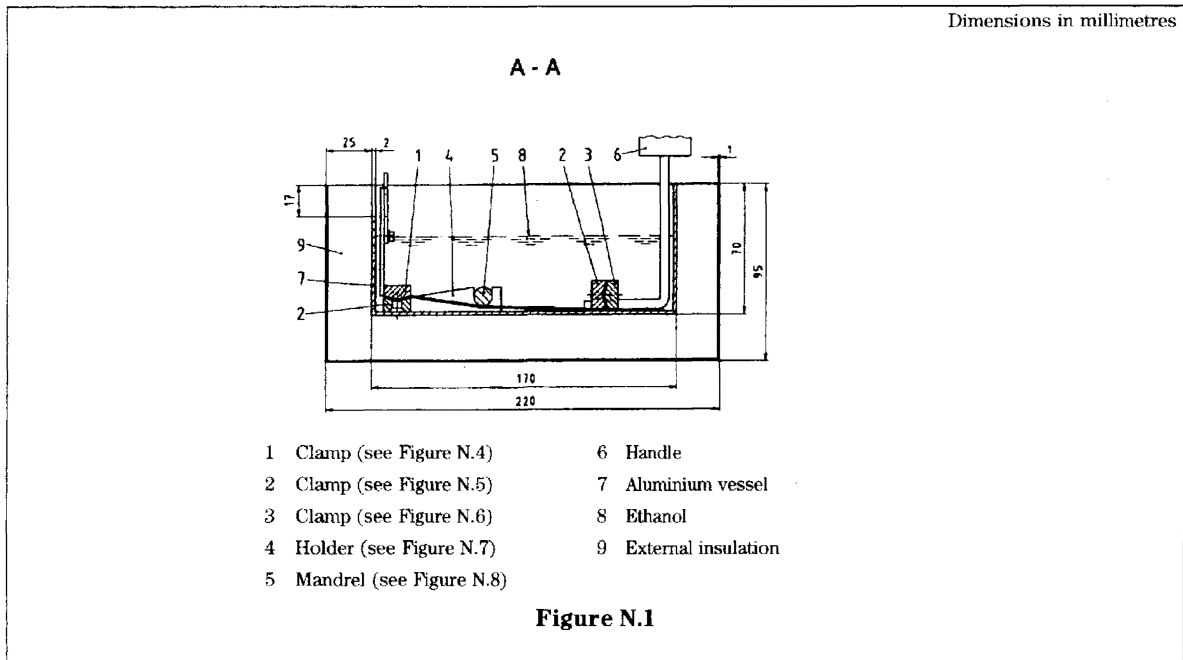

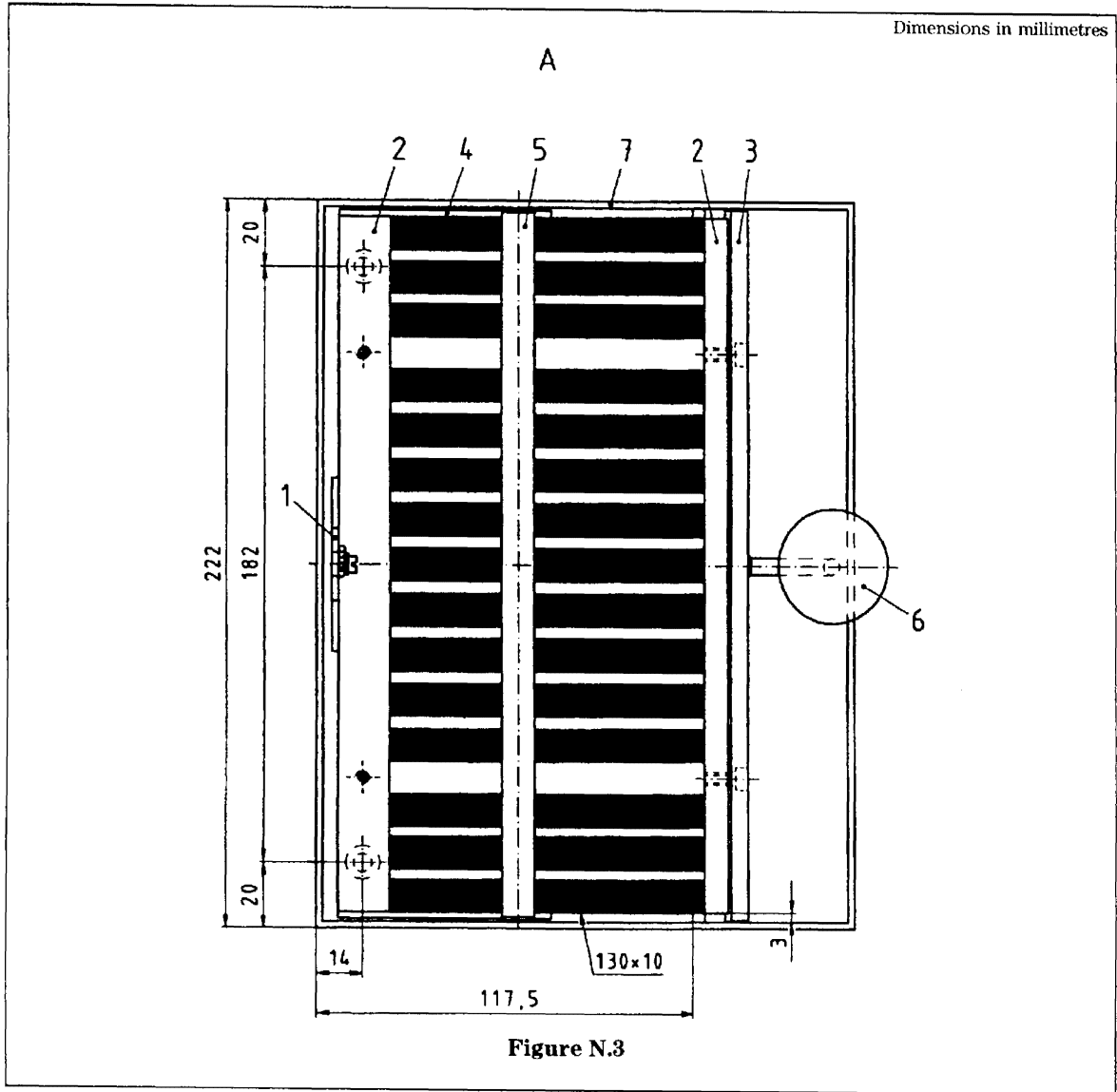

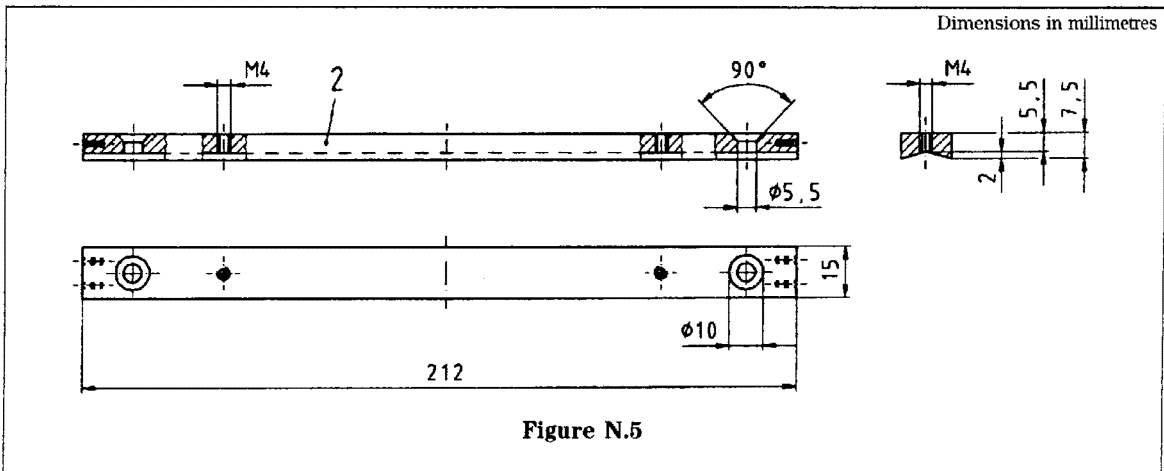
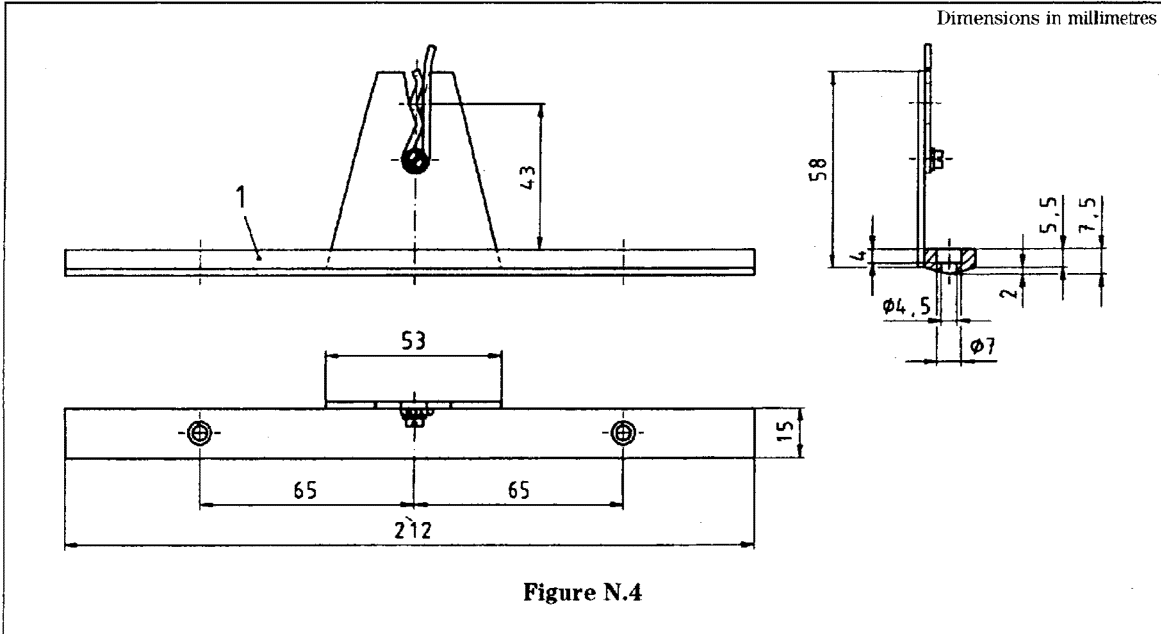

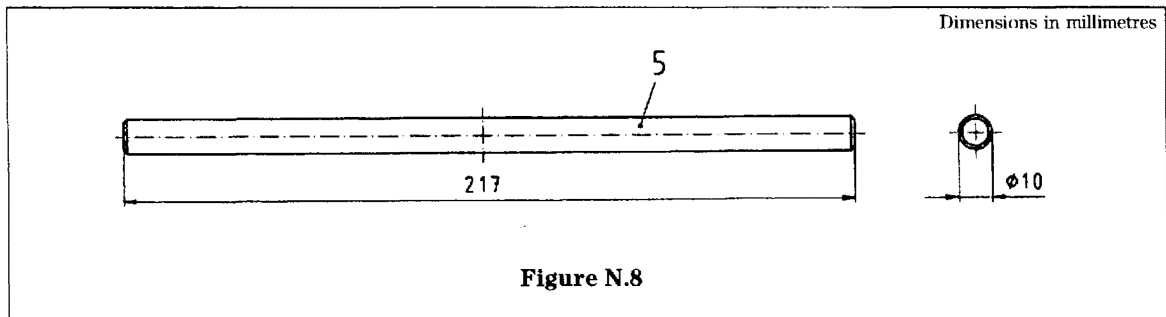
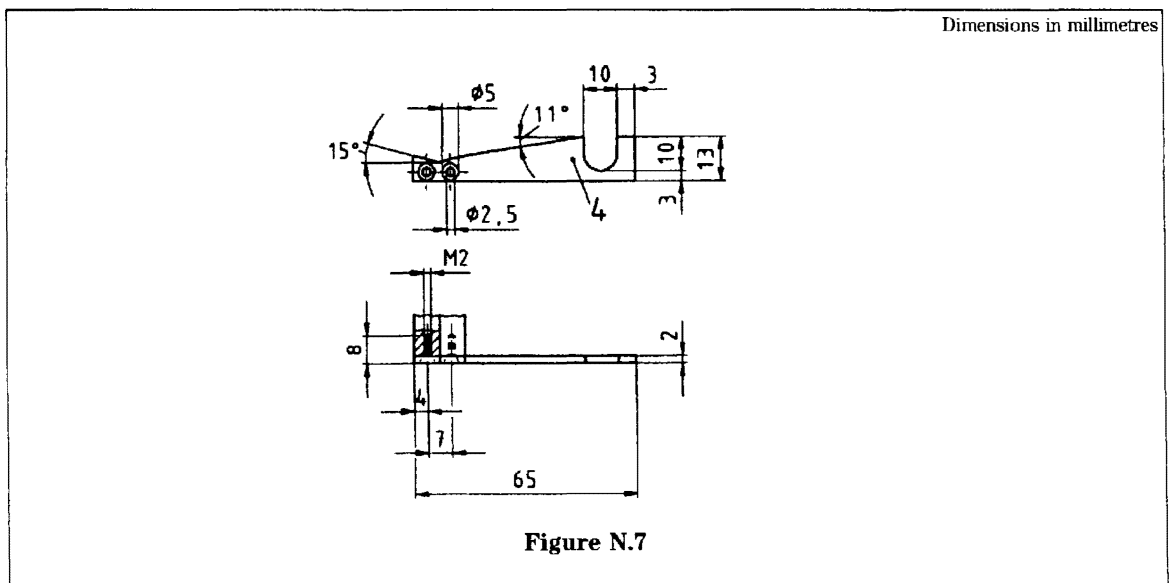
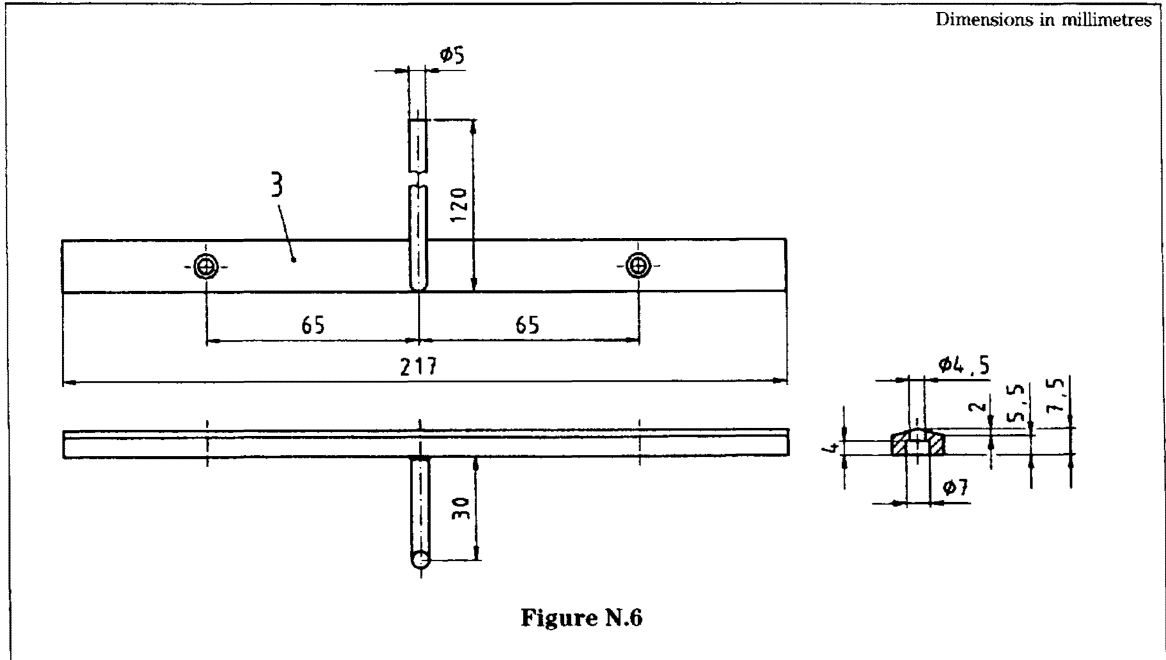

Annex P (normative)

Low temperature unrolling test

P.1 General

The test method consists of assessing any deleterious change in the structure of the specimens during the unrolling of a tape or shrinkable material at low temperature.

P.2 Apparatus

- a) *Thermostatically controlled oven*, according to ISO/DIS 188, normal oven method, which can be controlled at a temperature of $(50 \pm 2) ^\circ\text{C}$;
- b) *Temperature chamber* which can be controlled at the test temperature $\pm 2 ^\circ\text{C}$.

Chamber and oven shall be of sufficient size to allow test rolls or shrinkable materials to be suspended horizontally without restriction.

P.3 Sampling

The tape rolls or shrinkable materials shall be tested as delivered.

P.4 Procedure

The tape rolls and shrinkable materials shall be maintained for 24 h at $50 ^\circ\text{C}$ and subsequently for:

- a) 24 h at $-5 ^\circ\text{C}$ or the minimum product handling temperature as given by the manufacturer; or
- b) 24 h at $-20 ^\circ\text{C}$ for class L; or
- c) 24 h at agreed temperature for class VL.

After this treatment, the sample roll shall then be immediately and completely unrolled at a speed of approximately 100 mm/s on a flat surface.

The shrinkable material shall be unrolled according to the manufacturer's application instruction.

Examine for separation, tears and cracks in the material.

In the event of failure, the test shall be repeated with three other specimens. No further failure is allowed.

P.5 Expression of result

Report pass or fail.

Annex Q (normative)

Drip resistance of petrolatum tapes

Q.1 General

The test method consists of determining if any components of the petrolatum tape drip at $50 ^\circ\text{C}$.

Q.2 Apparatus

A thermostatically controlled oven according to ISO/DIS 188, normal oven method, which can be controlled at a temperature of $(50 \pm 2) ^\circ\text{C}$. The oven shall be of sufficient size to allow test specimens to be suspended vertically without restriction.

Q.3 Preparation of the test specimens

Cut three specimens of petrolatum tape of 150 mm in length and 50 mm wide or of tape with in the case of narrower tapes.

Q.4 Procedure

The test is carried out at $(50 \pm 2) ^\circ\text{C}$.

Suspend the three strips of petrolatum tape freely in the oven for 48 h.

After this period, observe any components which have dripped.

If any material has dripped, the test shall be repeated with five other specimens. No further dripping of components is allowed.

Q.5 Expression of result

Report pass or fail.

BS EN
12068:1999

BSI — British Standards Institution

BSI is the independent national body responsible for preparing British Standards. It presents the UK view on standards in Europe and at the international level. It is incorporated by Royal Charter.

Revisions

British Standards are updated by amendment or revision. Users of British Standards should make sure that they possess the latest amendments or editions.

It is the constant aim of BSI to improve the quality of our products and services. We would be grateful if anyone finding an inaccuracy or ambiguity while using this British Standard would inform the Secretary of the technical committee responsible, the identity of which can be found on the inside front cover. Tel: 0181 996 9000. Fax: 0181 996 7400.

BSI offers members an individual updating service called PLUS which ensures that subscribers automatically receive the latest editions of standards.

Buying standards

Orders for all BSI, international and foreign standards publications should be addressed to Customer Services. Tel: 0181 996 7000. Fax: 0181 996 7001.

In response to orders for international standards, it is BSI policy to supply the BSI implementation of those that have been published as British Standards, unless otherwise requested.

Information on standards

BSI provides a wide range of information on national, European and international standards through its Library and its Technical Help to Exporters Service. Various BSI electronic information services are also available which give details on all its products and services. Contact the Information Centre. Tel: 0181 996 7111. Fax: 0181 996 7048.

Subscribing members of BSI are kept up to date with standards developments and receive substantial discounts on the purchase price of standards. For details of these and other benefits contact Membership Administration. Tel: 0181 996 7002. Fax: 0181 996 7001.

Copyright

Copyright subsists in all BSI publications. BSI also holds the copyright, in the UK, of the publications of the international standardization bodies. Except as permitted under the Copyright, Designs and Patents Act 1988 no extract may be reproduced, stored in a retrieval system or transmitted in any form or by any means – electronic, photocopying, recording or otherwise – without prior written permission from BSI.

This does not preclude the free use, in the course of implementing the standard, of necessary details such as symbols, and size, type or grade designations. If these details are to be used for any other purpose than implementation then the prior written permission of BSI must be obtained.

If permission is granted, the terms may include royalty payments or a licensing agreement. Details and advice can be obtained from the Copyright Manager. Tel: 0181 996 7070.

BSI
389 Chiswick High Road
London
W4 4AL